

01 ONE

金属编织网

ARCHITECTURAL WOVEN WIRE MESH

采用优质不锈钢、铝合金、铜等，经纬编织而成。表面经过抛光或着色处理，具有防腐蚀、防火耐高温等优势。材质、孔型、颜色、尺寸均可按需定做。尺寸最宽8米，长度不限。建筑编织网主要应用在隔断、屏风、吊顶、内外幕墙、家具橱柜、电梯内壁、栏杆等室内外装饰。

Architectural Woven Wire Mesh is produced in high grade stainless steel, aluminium alloy and copper by weave. We can manufacture by your requirement. The width is max 8 meters, the length is no limited.

Architectural Woven Wire Mesh can either allow for openness and uninterrupted sight lines, or it can obscure and seclude areas, depending on the needs of the designer.

Architectural Woven Wire Mesh is used widely for internal and external decoration as space dividers, screens, ceilings, claddings, wall coverings, facades, elevator panel, railing infill, furnitures and so on.



SXY-4709

材质Material: 不锈钢SS 径丝Warp diameter: 1.0mm
纬丝Weft diameter: 1*4mm 径向间距Warp pitch: 4*4*8mm
纬向间距Weft pitch: 7mm 重量Weight: 5.2kg/m²

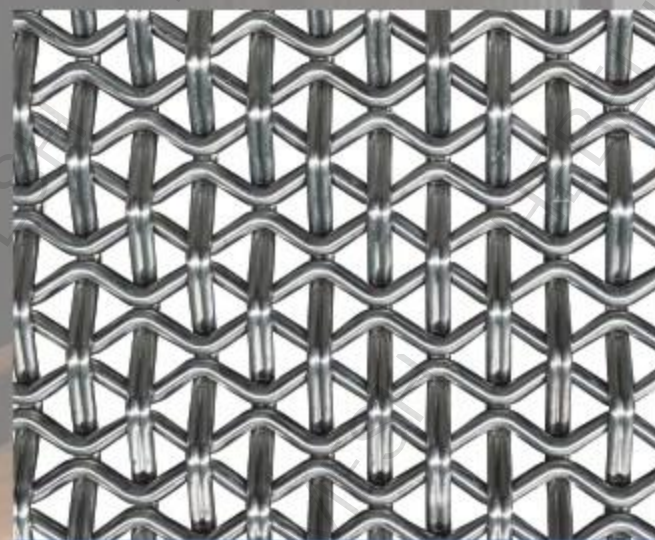

SXY-1628

材质Material: 不锈钢SS 径丝Warp diameter: 1.2mm*2
纬丝Weft diameter: 2mm 径向间距Warp pitch: 5mm
纬向间距Weft pitch: 8mm 重量Weight: 9.2kg/m²



SXY-2810

材质Material: 不锈钢SS 径丝Warp diameter: 2.8mm
纬丝Weft diameter: 2.8mm 径向间距Warp pitch: 12mm
纬向间距Weft pitch: 12mm 重量Weight: 8.4kg/m²

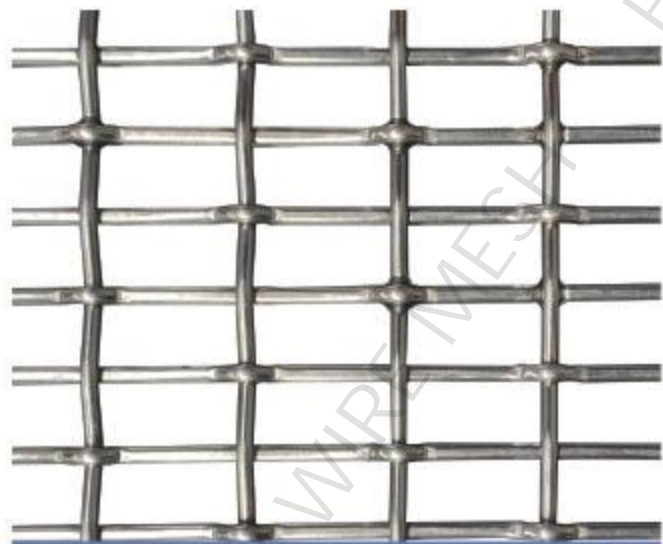

SXY-1580

材质Material:不锈钢SS 径丝Warp diameter:2mm
纬丝Weft diameter:2mm 径向间距Warp pitch:15mm
纬向间距Weft pitch:8mm 重量Weight:4.6kg/m²

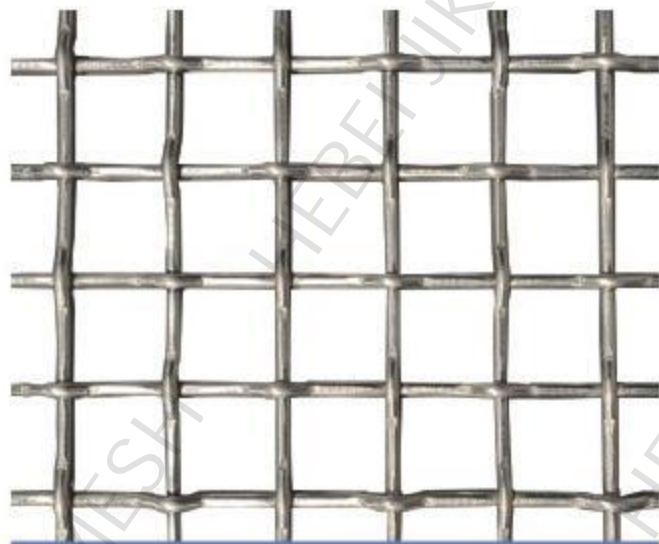

SXY-25150

材质Material:不锈钢SS 径丝Warp diameter:2.5mm
纬丝Weft diameter:2.5mm 径向间距Warp pitch:15mm
纬向间距Weft pitch:15mm 重量Weight:4kg/m²

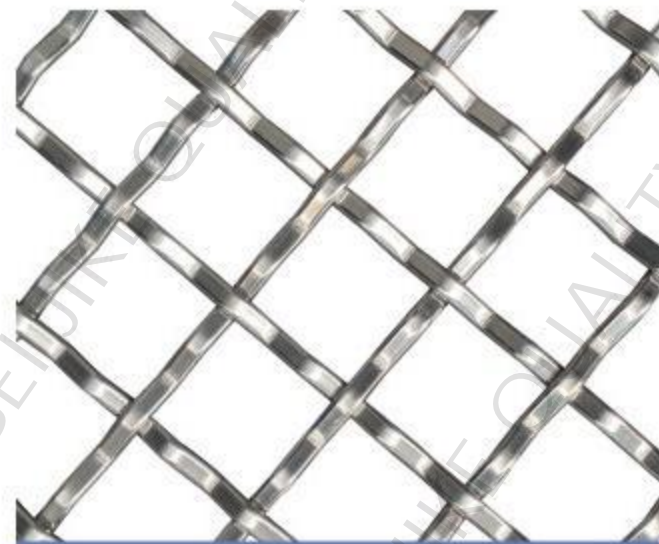

SXY-1530

材质Material:不锈钢SS 径丝Warp diameter:1.5*3mm
纬丝Weft diameter:1.5*3mm 径向间距Warp pitch:18mm
纬向间距Weft pitch:18mm 重量Weight:4.5kg/m²



SXY-1812

材质Material:不锈钢SS 径丝Warp diameter:1.8mm
纬丝Weft diameter:1.8mm 径向间距Warp pitch:12mm
纬向间距Weft pitch:12mm 重量Weight:3.3kg/m²



SXY-1610

材质Material:不锈钢SS 径丝Warp diameter:1.6*1.6mm
纬丝Weft diameter:1.6*1.6mm 径向间距Warp pitch:10mm
纬向间距Weft pitch:10mm 重量Weight:3.2kg/m²



SXY-1830

材质Material:不锈钢SS 径丝Warp diameter:1.8*3mm
纬丝Weft diameter:1.8*3mm 径向间距Warp pitch:10mm
纬向间距Weft pitch:10mm 重量Weight:7.3kg/m²

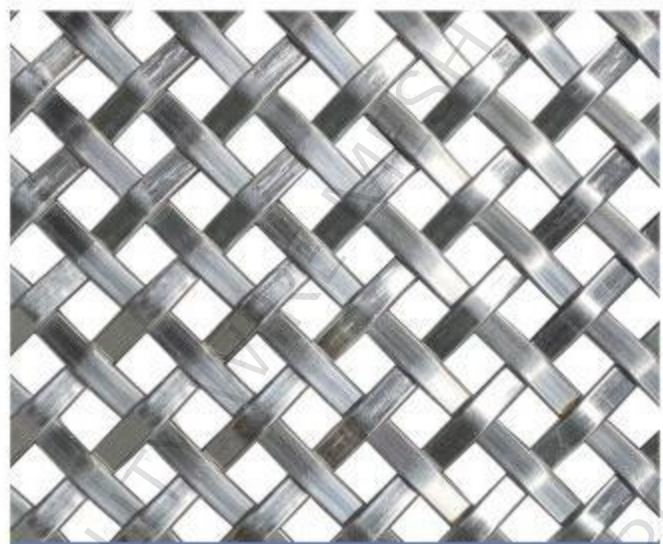

SXY-1409

材质Material:不锈钢SS 径丝Warp diameter:1*4mm
纬丝Weft diameter:1*4mm 径向间距Warp pitch:9mm
纬向间距Weft pitch:9mm 重量Weight:7.15kg/m²

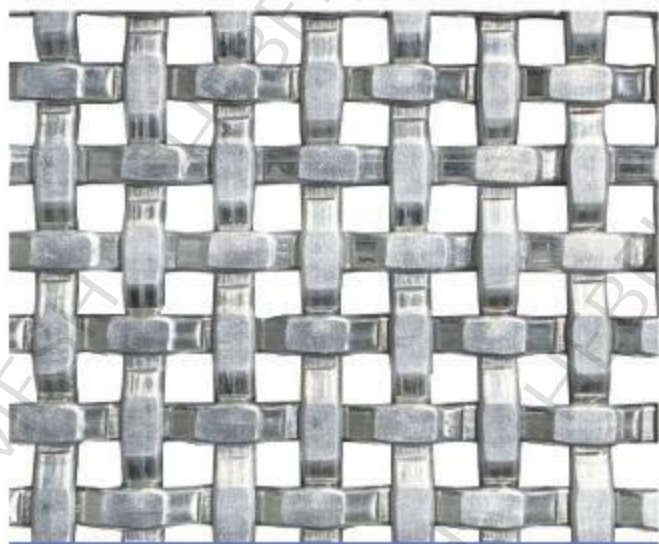

SXY-8535

材质Material:不锈钢SS 径丝Warp diameter:3.4*1.1mm
纬丝Weft diameter:3.4*1.1mm 径向间距Warp pitch:6.6mm
纬向间距Weft pitch:6.6mm 重量Weight:11.55kg/m²

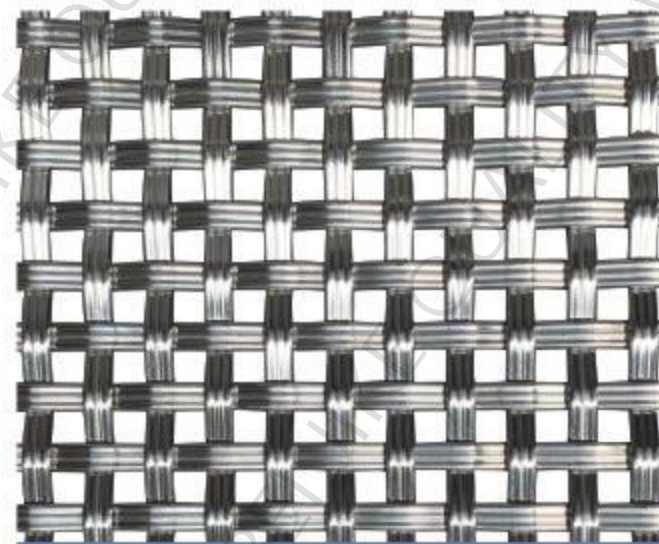

SXY-1230

材质Material:不锈钢SS 径丝Warp diameter:1*3mm
纬丝Weft diameter:1*3mm 径向间距Warp pitch:6mm
纬向间距Weft pitch:6mm 重量Weight:11.7kg/m²



SXY-2020

材质Material:不锈钢SS 径丝Warp diameter:2.0mm
纬丝Weft diameter:2.0mm 径向间距Warp pitch:8+20mm
纬向间距Weft pitch:8+20mm 重量Weight:3.62kg/m²

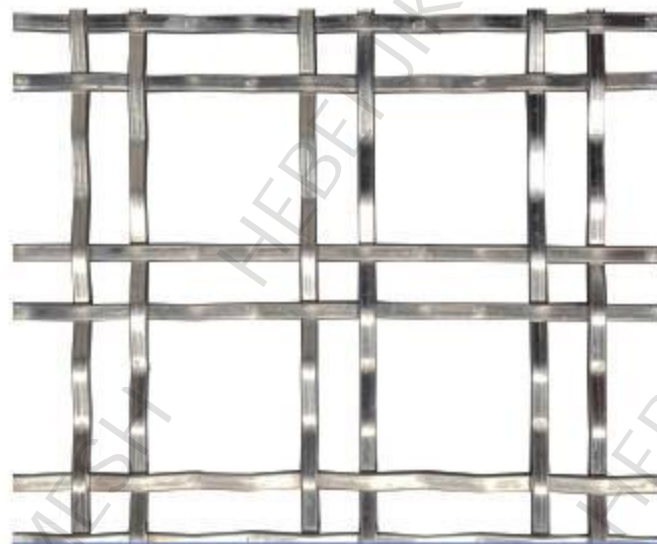

SXY-1030

材质Material:不锈钢SS 径丝Warp diameter:1.5*3mm
纬丝Weft diameter:1.5*3mm 径向间距Warp pitch:10+30mm
纬向间距Weft pitch:10+30mm 重量Weight:4kg/m²

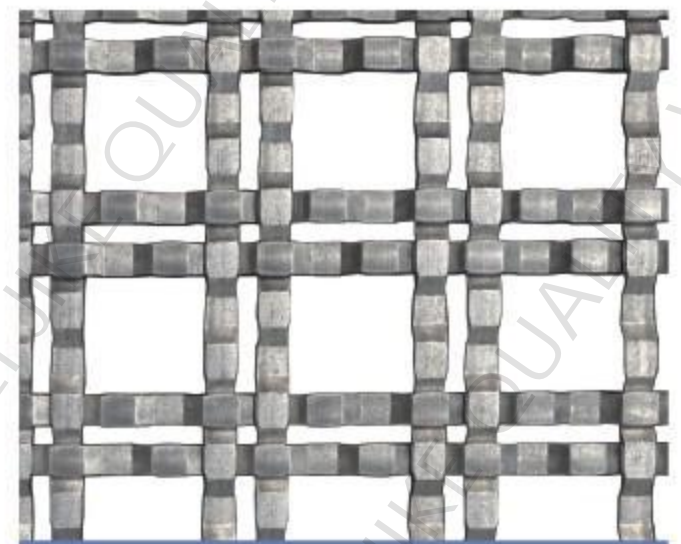

SXY-1037

材质Material:不锈钢SS 径丝Warp diameter:1x3.7mm
纬丝Weft diameter:1.5mm 径向间距Warp pitch:6+18mm
纬向间距Weft pitch:6+18mm 重量Weight:11.3kg/m²



SXY-1748

材质Material:不锈钢SS 径丝Warp diameter:1.7mm
纬丝Weft diameter:2mm 径向间距Warp pitch:4.8mm
纬向间距Weft pitch:46mm 重量Weight: 9.4kg/m²

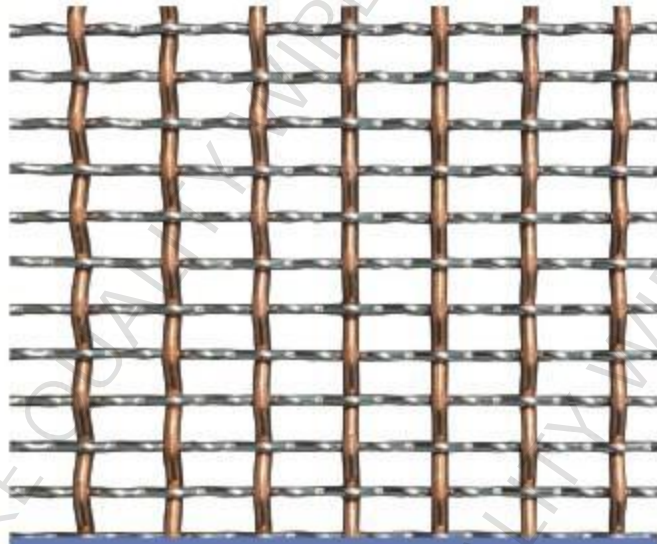

SXY-1510

材质Material:不锈钢SS+铜 径丝Warp diameter:1.5mm
纬丝Weft diameter:1mm 径向间距Warp pitch:8mm
纬向间距Weft pitch:4.2mm 重量Weight:3.5kg/m²

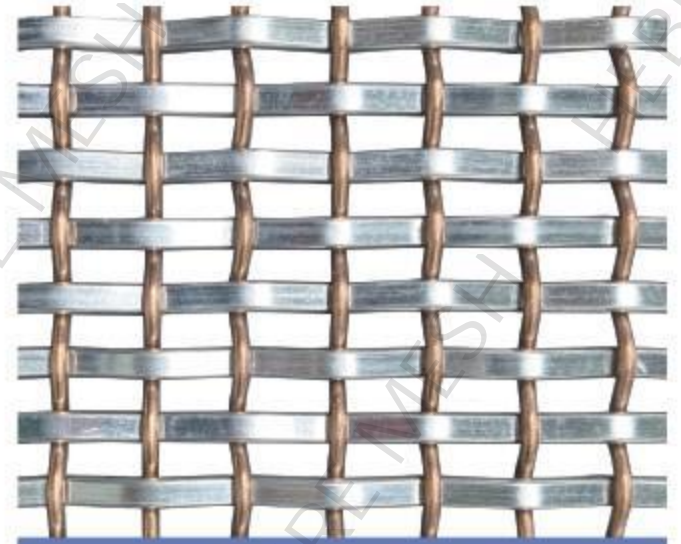

SXY-1345

材质Material:不锈钢SS+铜 径丝Warp diameter:1.5mm
纬丝Weft diameter:1*3mm 径向间距Warp pitch:8mm
纬向间距Weft pitch:7mm 重量Weight:5.4kg/m²



SXY-1252

材质Material:不锈钢SS 径丝Warp diameter:1*2.5mm
纬丝Weft diameter:2.0mm 径向间距Warp pitch:17.5mm
纬向间距Weft pitch:5mm 重量Weight:6.22kg/m²



SXY-1224

材质Material:不锈钢SS 径丝Warp diameter:1.2*2.4mm*3
纬丝Weft diameter:1.2*2.4*3 径向间距Warp pitch:10mm
纬向间距Weft pitch:10mm 重量Weight:13.7kg/m²

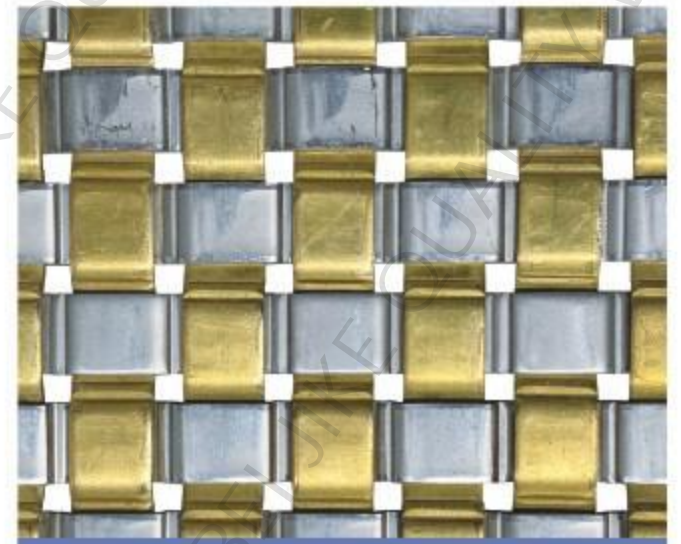

SXY-8195

材质Material:不锈钢SS+铜
扁条直径Flat diameter:1.5*9.5mm
扁条间距Flat pitch:12.8mm 重量Weight:18.4kg/m²



SXY-6212

材质Material:不锈钢SS 径丝Warp diameter:1.2mm*2
纬丝Weft diameter:2.0mm径向间距Warp pitch:17.5mm
纬向间距Weft pitch:4mm 重量Weight:7.4kg/m²



SXY-6212B

材质Material:不锈钢SS 径丝Warp diameter:1.2mm*2
纬丝Weft diameter:2.0mm径向间距Warp pitch:17.5mm
纬向间距Weft pitch:4mm 重量Weight:7.4kg/m²



SXY-6630

材质Material:不锈钢SS 径丝Warp diameter:1.5mm
纬丝Weft diameter:2.0mm 径向间距Warp pitch:17.5mm
纬向间距Weft pitch:4mm 重量Weight:7.2kg/m²

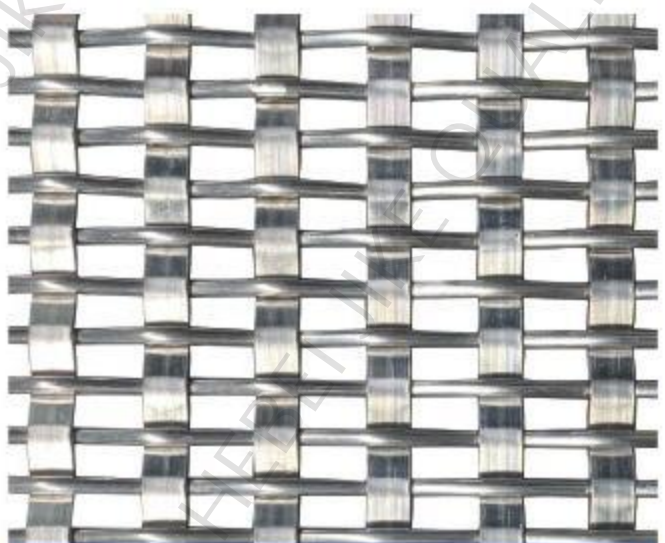

SXY-1035

材质Material:不锈钢SS 径丝Warp diameter:1*4mm
纬丝Weft diameter:1.6mm径向间距Warp pitch:10mm
纬向间距Weft pitch:4.5mm 重量Weight:6.8kg/m²



SXY-2124

材质Material:不锈钢SS 径丝Warp diameter:2.0mm
纬丝Weft diameter:1.2*4mm径向间距Warp pitch:5mm
纬向间距Weft pitch:4mm 重量Weight:13.1kg/m²



SXY-6230

材质Material:不锈钢SS 径丝Warp diameter:3.0mm
纬丝Weft diameter:(6+12)*1.0mm径向间距Warp pitch:6.2mm
纬向间距Weft pitch:18mm 重量Weight:17.7kg/m²



SXY-1615

材质Material:不锈钢SS 径丝Warp diameter:1.6mm
纬丝Weft diameter:1.5*3mm径向间距Warp pitch:10mm
纬向间距Weft pitch:3mm 重量Weight:13.8kg/m²



SXY-1717

材质Material:不锈钢SS 径丝Warp diameter:1x7mm
纬丝Weft diameter:1x7mm径向间距Warp pitch:17mm
纬向间距Weft pitch:7mm 重量Weight:11.3kg/m²

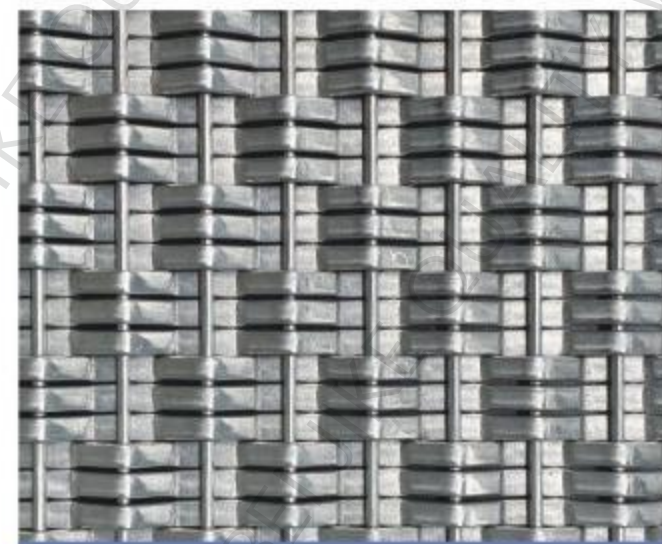

SXY-1690

材质Material:不锈钢SS 径丝Warp diameter:1.6mm
纬丝Weft diameter:1.5*3mm径向间距Warp pitch:10mm
纬向间距Weft pitch:9mm 重量Weight:13.8kg/m²

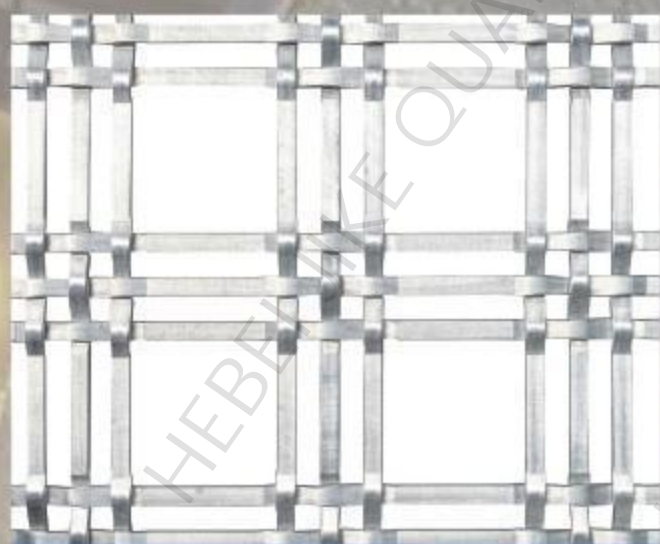
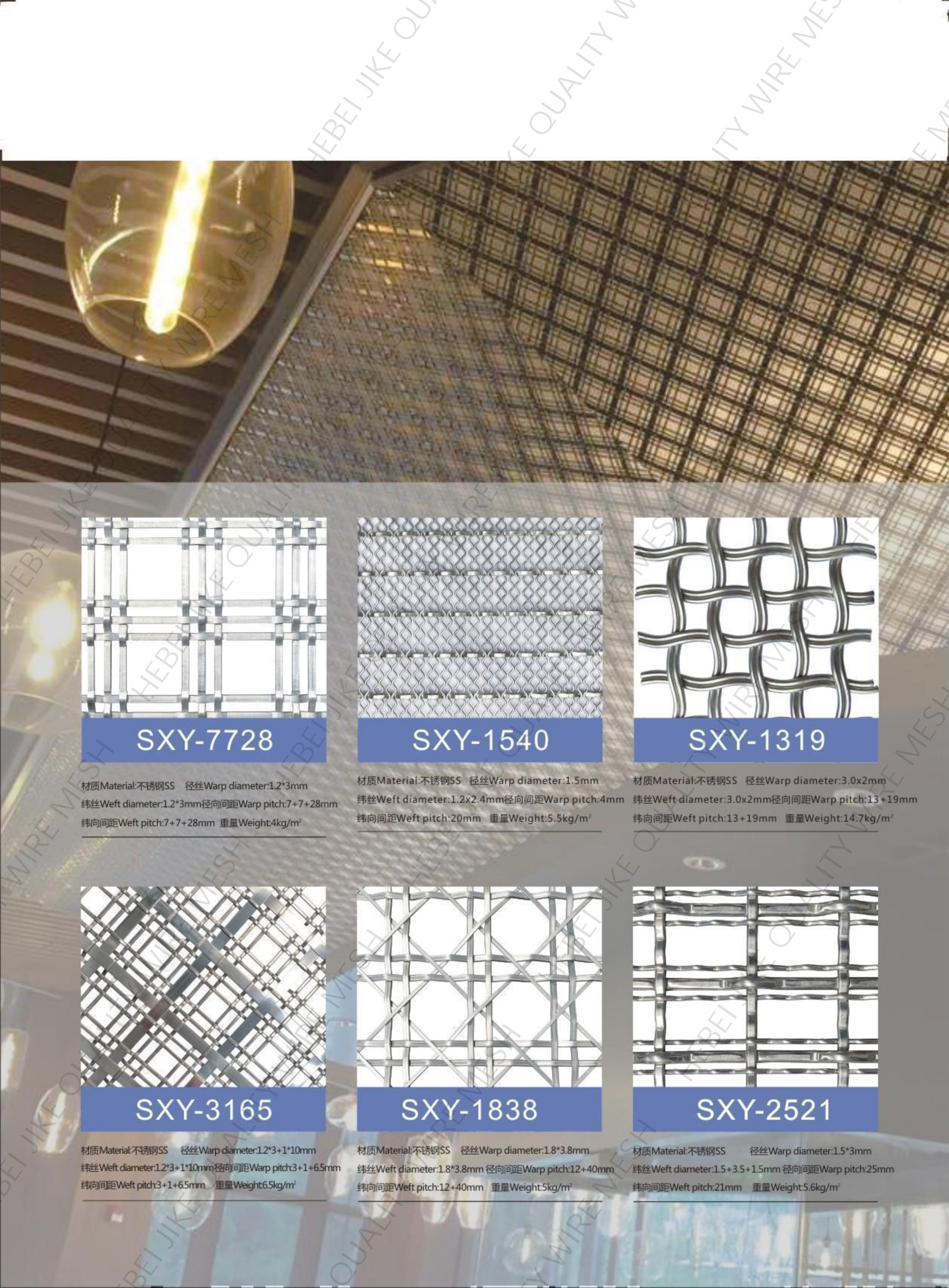

SXY-7728

材质Material:不锈钢SS 径丝Warp diameter:1.2*3mm
纬丝Weft diameter:1.2*3mm 径向间距Warp pitch:7+7+28mm
纬向间距Weft pitch:7+7+28mm 重量Weight:4kg/m²



SXY-1540

材质Material:不锈钢SS 径丝Warp diameter:1.5mm
纬丝Weft diameter:1.2x2.4mm 径向间距Warp pitch:4mm
纬向间距Weft pitch:20mm 重量Weight:5.5kg/m²



SXY-1319

材质Material:不锈钢SS 径丝Warp diameter:3.0x2mm
纬丝Weft diameter:3.0x2mm 径向间距Warp pitch:13+19mm
纬向间距Weft pitch:13+19mm 重量Weight:14.7kg/m²



SXY-3165

材质Material:不锈钢SS 径丝Warp diameter:1.2*3+1*10mm
纬丝Weft diameter:1.2*3+1*10mm 径向间距Warp pitch:3+1+6.5mm
纬向间距Weft pitch:3+1+6.5mm 重量Weight:6.5kg/m²

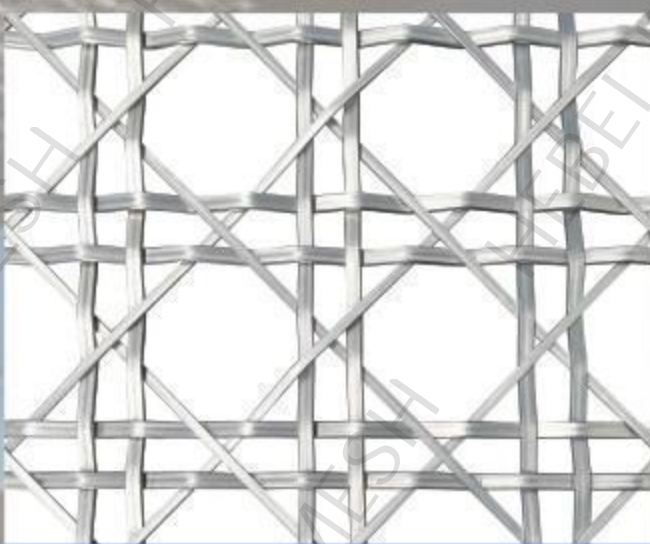

SXY-1838

材质Material:不锈钢SS 径丝Warp diameter:1.8*3.8mm
纬丝Weft diameter:1.8*3.8mm 径向间距Warp pitch:12+40mm
纬向间距Weft pitch:12+40mm 重量Weight:5kg/m²

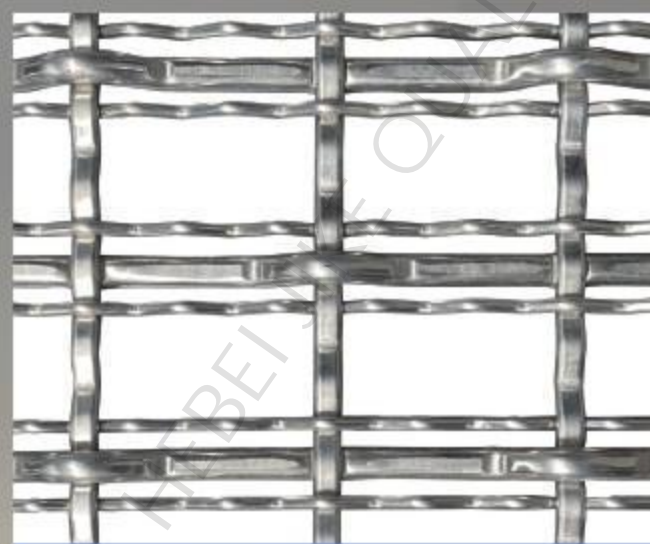

SXY-2521

材质Material:不锈钢SS 径丝Warp diameter:1.5*3mm
纬丝Weft diameter:1.5+3.5+1.5mm 径向间距Warp pitch:25mm
纬向间距Weft pitch:21mm 重量Weight:5.6kg/m²

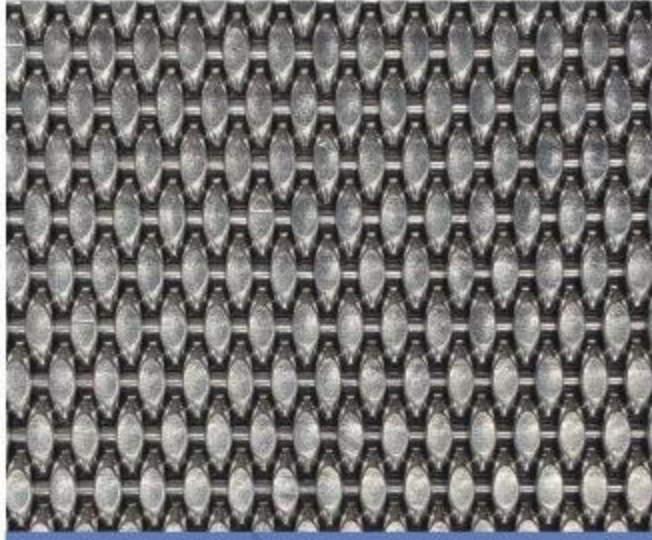

SXY-1520

材质Material:不锈钢SS 径丝Warp diameter:1.5mm
纬丝Weft diameter:2mm 径向间距Warp pitch:5mm
纬向间距Weft pitch:2mm 重量Weight:15.5kg/m²

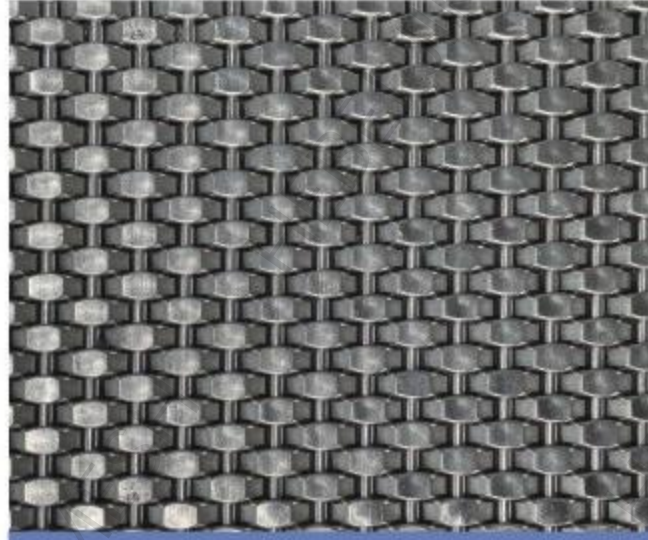

SXY-6148

材质Material:不锈钢SS 径丝Warp diameter:1.5mm
纬丝Weft diameter:2.7*1.6mm 径向间距Warp pitch:9.3mm
纬向间距Weft pitch:2.8mm 重量Weight:11kg/m²

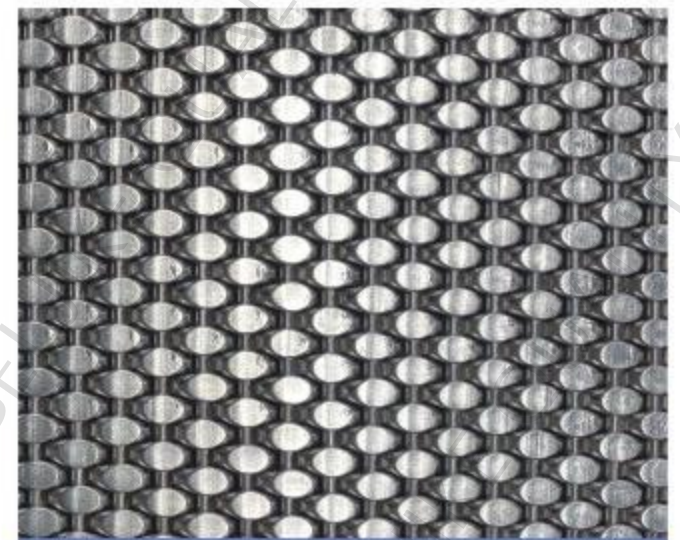

SXY-9930

材质Material:不锈钢SS 径丝Warp diameter:1.5mm
纬丝Weft diameter:2.5mm 径向间距Warp pitch:4.8mm
纬向间距Weft pitch:2.5mm 重量Weight:18.7kg/m²



SXY-2520

材质Material:不锈钢SS 径丝Warp diameter:2.5mm
纬丝Weft diameter:2mm 径向间距Warp pitch:7mm
纬向间距Weft pitch:2mm 重量Weight:18.3kg/m²



SXY-4333

材质Material:不锈钢SS 径丝Warp diameter:2.0mm
纬丝Weft diameter:1.5mm 径向间距Warp pitch:7mm
纬向间距Weft pitch:1.5mm 重量Weight:12.7kg/m²



SXY-0815

材质Material:不锈钢SS 径丝Warp diameter:1.5mm
纬丝Weft diameter:1.5mm 径向间距Warp pitch:8mm
纬向间距Weft pitch:1.5mm 重量Weight:11.3kg/m²



SXY-1515

材质Material:不锈钢SS+铜 径丝Warp diameter:1.6*1mm
纬丝Weft diameter:1.5*2mm 径向间距Warp pitch:5mm
纬向间距Weft pitch:8mm 重量Weight:12.78kg/m²

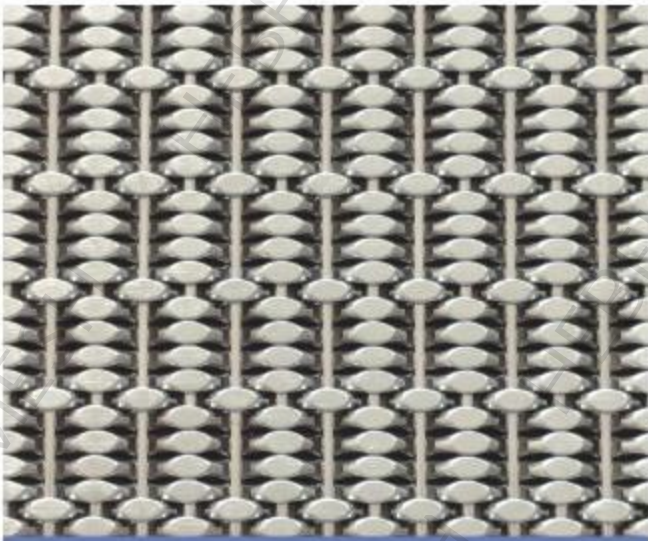

SXY-6512

材质Material:不锈钢SS 径丝Warp diameter:1.5mm
纬丝Weft diameter:1.45*42mm*1 径向间距Warp pitch:4mm
纬向间距Weft pitch:7.8mm 重量Weight:12.8kg/m²

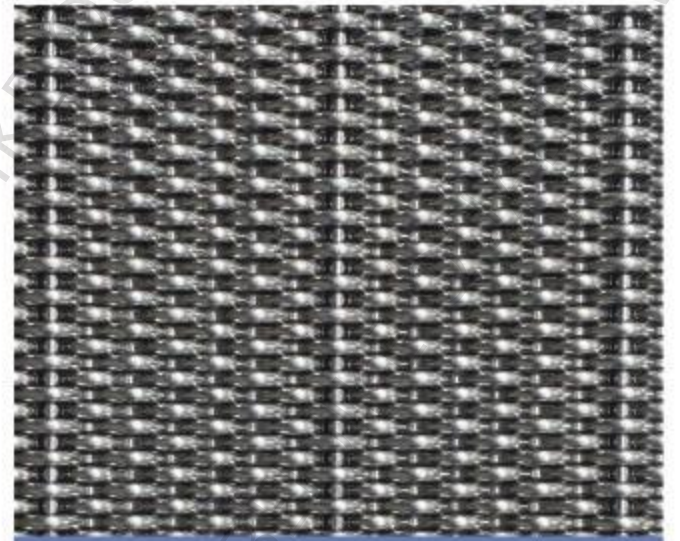

SXY-1526

材质Material:不锈钢SS 径丝Warp diameter:1.5mm
纬丝Weft diameter:1.5mm 径向间距Warp pitch:26.5mm
纬向间距Weft pitch:1.5mm 重量Weight:10kg/m²





SXY-405

材质Material:不锈钢SS 绳径Cable diameter:2.0mm*4
杆径Rod diameter:3.0mm 绳距Cable pitch:50mm
杆距Rod pitch:6mm 重量Weight:11.56kg/m²



SXY-436

材质Material:不锈钢SS 绳径Cable diameter:1.0mm*4
杆径Rod diameter:2.0mm 绳距Cable pitch:36mm
杆距Rod pitch:4mm 重量Weight:7kg/m²



SXY-436S

材质Material:不锈钢SS 径丝Warp diameter:1.0mm*4
纬丝Weft diameter:2.0mm 径向间距Warp pitch:36mm
纬向间距Weft pitch:4mm 重量Weight:7kg/m²



SXY-426

材质Material:不锈钢SS 绳径Cable diameter:0.75mm*4
杆径Rod diameter:1.5mm 绳距Cable pitch:26.4mm
杆距Rod pitch:3mm 重量Weight:5.3kg/m²



SXY-3810

材质Material:不锈钢SS 绳径Cable diameter:2.0mm*3
杆径Rod diameter:3mm 绳距Cable pitch:80mm
杆距Rod pitch:10mm 重量Weight:6.6kg/m²



SXY-3810S

材质Material:不锈钢SS 径丝Warp diameter:2.0mm*3
纬丝Weft diameter:3.0mm 径向间距Warp pitch:80mm
纬向间距Weft pitch:10mm 重量Weight:6.6kg/m²



SXY-1735

材质Material:不锈钢SS 绳径Cable diameter:2.0mm
杆径Rod diameter:1.5mm 绳距Cable pitch:17.5mm
杆距Rod pitch:5mm 重量Weight:5.6kg/m²



SXY-1715

材质Material:不锈钢SS 绳径Cable diameter:2.0mm
杆径Rod diameter:1.5mm 绳距Cable pitch:17.5mm
杆距Rod pitch:1.5mm 重量Weight:11kg/m²



SXY-1715S

材质Material:不锈钢SS 径丝Warp diameter:2.0mm
纬丝Weft diameter:1.5mm 径向间距Warp pitch:17.5mm
纬向间距Weft pitch:1.5mm 重量Weight:11kg/m²



SXY-1608

材质Material:不锈钢SS 绳径Cable diameter:2.5mm
杆径Rod diameter:2.0mm 绳距Cable pitch:6mm
杆距Rod pitch:8mm 重量Weight:8.1kg/m²

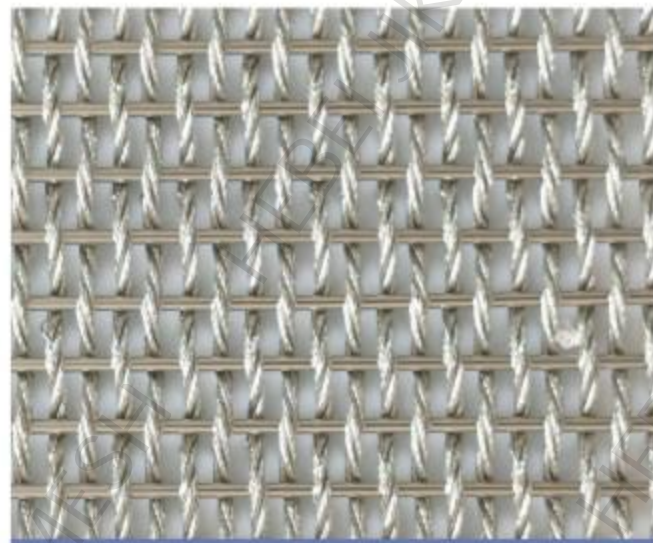

SXY-1706

材质Material:不锈钢SS 绳径Cable diameter:1.6mm
杆径Rod diameter:1.5mm 绳距Cable pitch:3mm
杆距Rod pitch:6mm 重量Weight:4.5kg/m²



SXY-4813

材质Material:不锈钢SS 绳径Cable diameter:1.5mm*3
杆径Rod diameter:2.5mm 绳距Cable pitch:5mm
杆距Rod pitch:7mm 重量Weight:14.2kg/m²

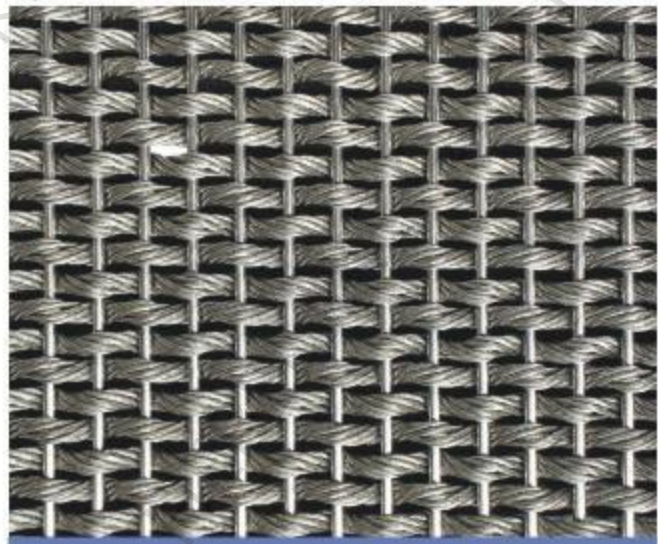

SXY-1720

材质Material:不锈钢SS 绳径Cable diameter:2.0mm
杆径Rod diameter:1.5mm 绳距Cable pitch:3.5mm
杆距Rod pitch:5mm 重量Weight:9.2kg/m²

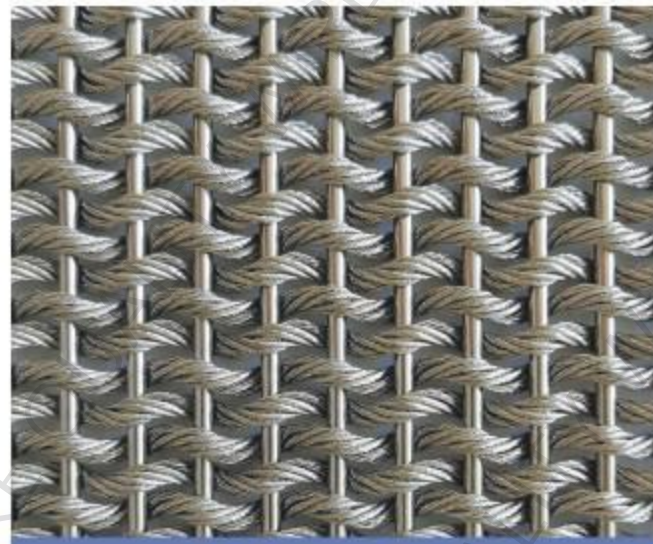

SXY-4014

材质Material:不锈钢SS 绳径Cable diameter:3.0mm
杆径Rod diameter:3.0mm 绳距Cable pitch:4.0mm
杆距Rod pitch:14mm 重量Weight:16.9kg/m²

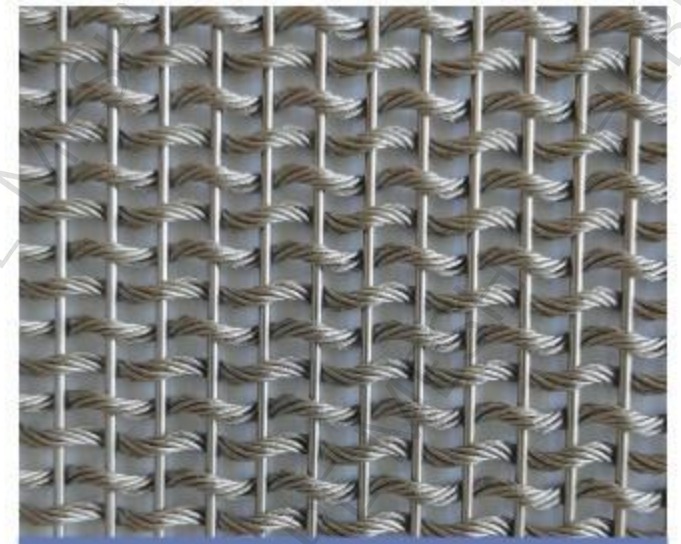

SXY-4525

材质Material:不锈钢SS 绳径Cable diameter:2.5mm
杆径Rod diameter:2.0mm 绳距Cable pitch:6.0mm
杆距Rod pitch:8.0mm 重量Weight:8kg/m²

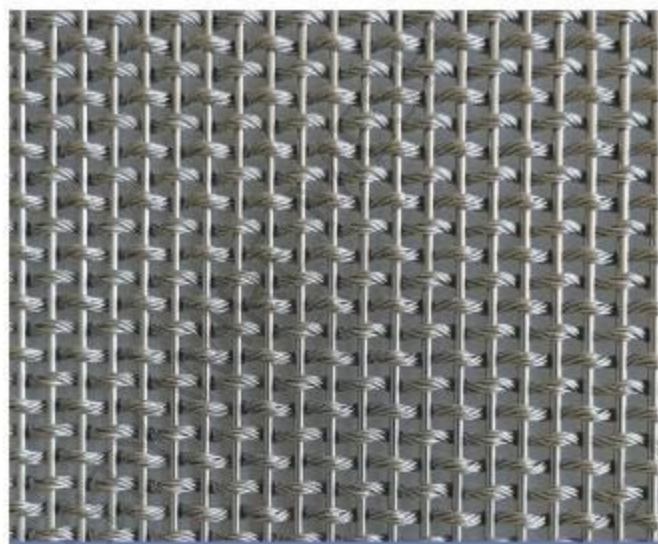

SXY-4250

材质Material:不锈钢SS 绳径Cable diameter:2.5mm
杆径Rod diameter:2.0mm 绳距Cable pitch:5.0mm
杆距Rod pitch:6.0mm 重量Weight:12.1kg/m²



01 ONE

效果展示

RESULTS SHOW



02 TWO

金属网帘-S型

COIL DRAPERY

采用优质低碳钢丝、铝合金、不锈钢丝，螺旋编织而成。表面经过抛光或烤漆处理，具有防火耐高温、不褪色、垂感好、自由拉伸等优点。

材质、网孔大小、颜色以及尺寸都可按需定做。尺寸最高可达6米，宽度不限。

金属网帘应用在隔断、屏风、窗帘、吊顶造型等室内外装饰。

Coil drapery is produced in round spirals wire by weave.

The material is high grade mild steel wire, aluminium alloy, stainless steel.

We can manufacture by your requirement. The height is max 6 meters, the width is no limited.

Coil drapery is used widely for interior and exterior decoration as dividers, partitions, mesh curtains, ceilings and so on.

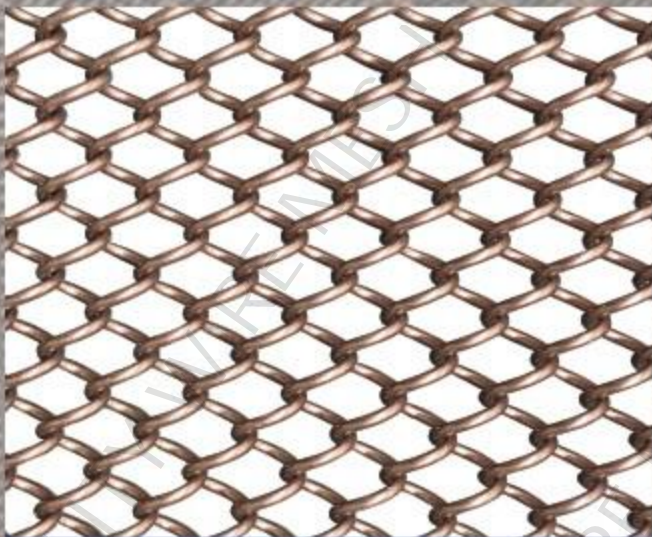

SXY-01-04L

材质(Material):铝Aluminium
丝径(Wire diameter):1.2mm 孔径(Aperture):4mm
重量(Weight):1.5kg/M²

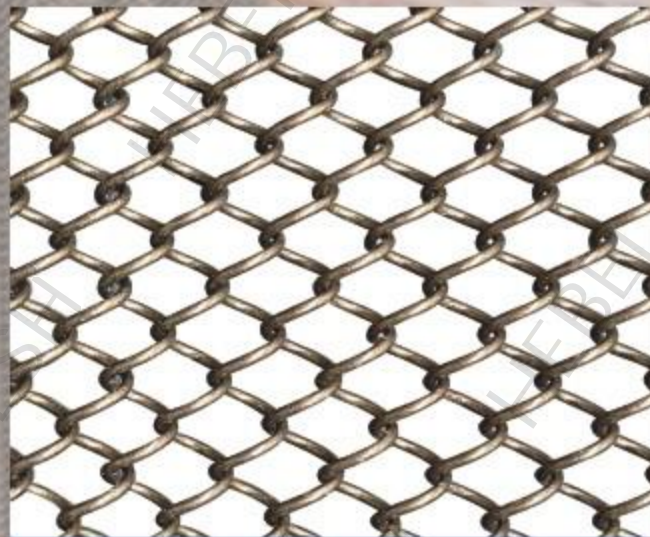

SXY-02-04T

材质(Material):低碳钢丝Steel Wire
丝径(Wire diameter):1.0mm 孔径(Aperture):4mm
重量(Weight):3.3kg/m²



SXY-03-08L

材质(Material):铝Aluminium
丝径(Wire diameter):2.0mm 孔径(Aperture):8mm
重量(Weight):3.2kg/m²

02 TWO

效果展示

RESULTS SHOW

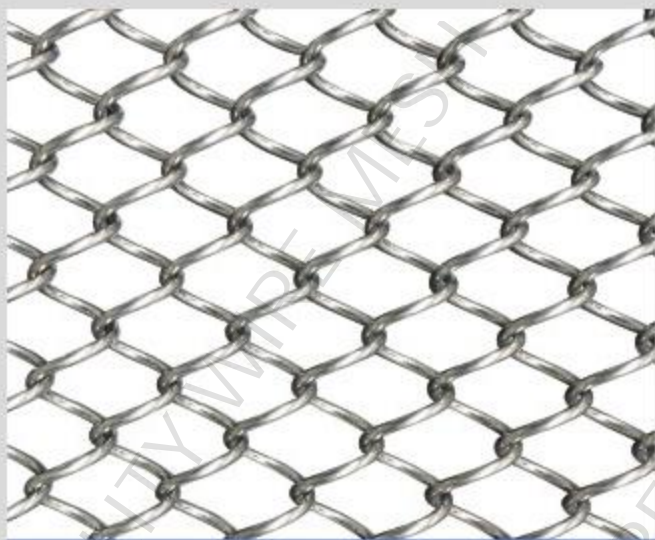
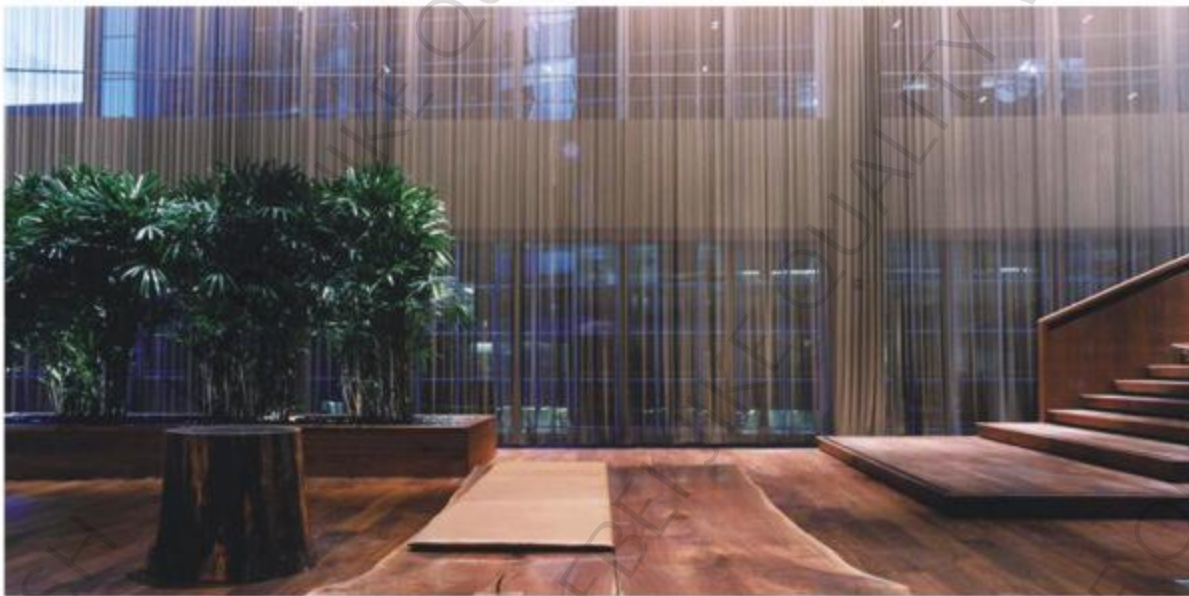
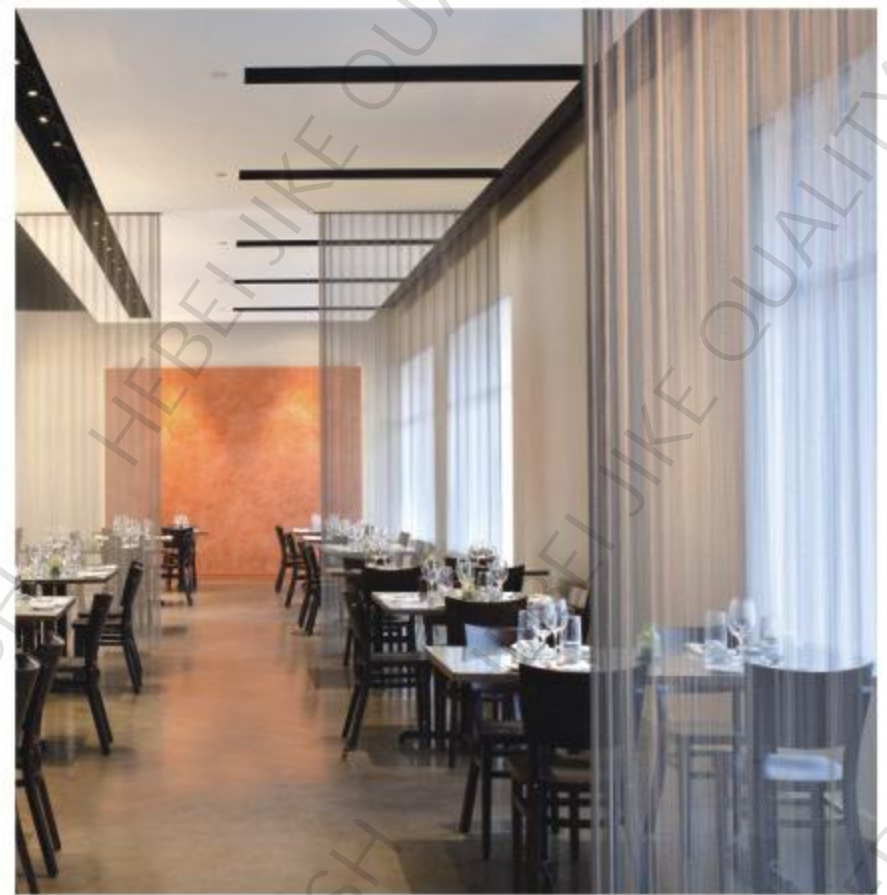

SXY-04-06B

材质(Material):不锈钢SS304
丝径(Wire diameter):1.2mm 孔径(Aperture):6mm
重量(Weight):3.6kg/m²

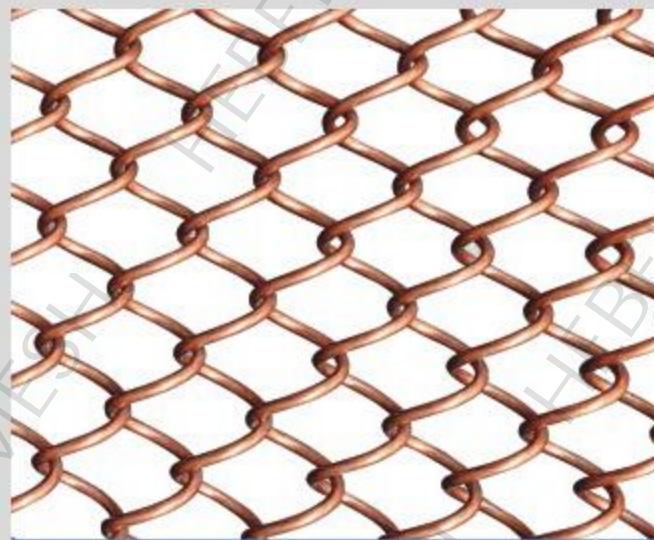

SXY-05-06L

材质(Material):铝Aluminium
丝径(Wire diameter):1.2mm 孔径(Aperture):6mm
重量(Weight):1.5kg/m²

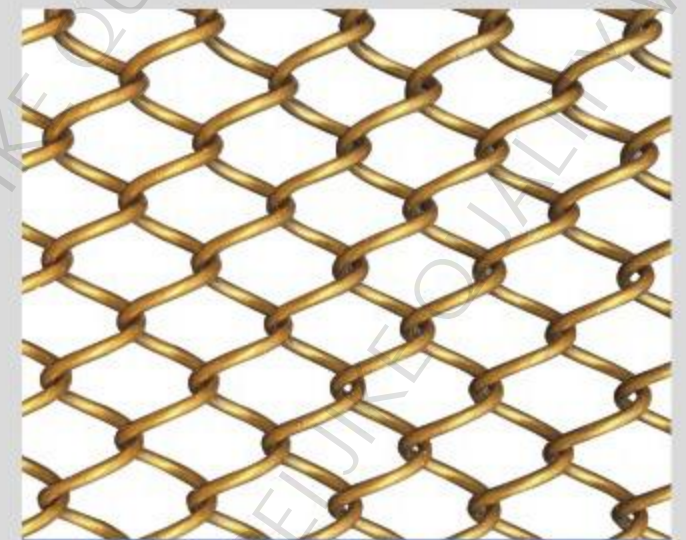

SXY-06-06T

材质(Material):低碳钢丝Steel wire
丝径(Wire diameter):1.2mm 孔径(Aperture):6mm
重量(Weight):3.6kg/m²

03 THREE

金属网帘-V型

SPIRAL MESH

采用优质低碳钢、不锈钢，螺旋套织而成。表面经过抛光或着色处理，具有防火耐高温、防腐蚀、自由伸拉等优点。材质、孔型、尺寸、颜色均可按需定做。尺寸最宽6米，长度不限。

金属螺旋网广泛应用于隔断、屏风、天花吊顶、内外幕墙等室内外装饰。

Spiral mesh, also named conveyer belt, is produced from flat or round ribbon spirals, which are connected to a straight or crimped round rod, welded on edges.

The material is mild steel and stainless steel. We can manufacture to order by your requirement.

The width is max 6 meters, the length is no limited.

Spiral mesh is used widely for interior and exterior decoration as space dividers, partitions, ceilings, wall cladding, facades, mesh curtains and so on.



SXY-SS10

材质(Material): 不锈钢SS304, 316
穿条直径(Cross diameter): 1.2mm
螺旋直径(Spiral diameter): 1.0mm
穿条间距(Cross pitch): 4mm
螺旋间距(Spiral pitch): 4mm
重量(Weight): 19kg/m²



SXY-SS11

材质(Material): 不锈钢SS304, 316
穿条直径(Cross diameter): 1.6mm
孔径(Aperture): 10x50mm
重量(Weight): 1.2kg/m²

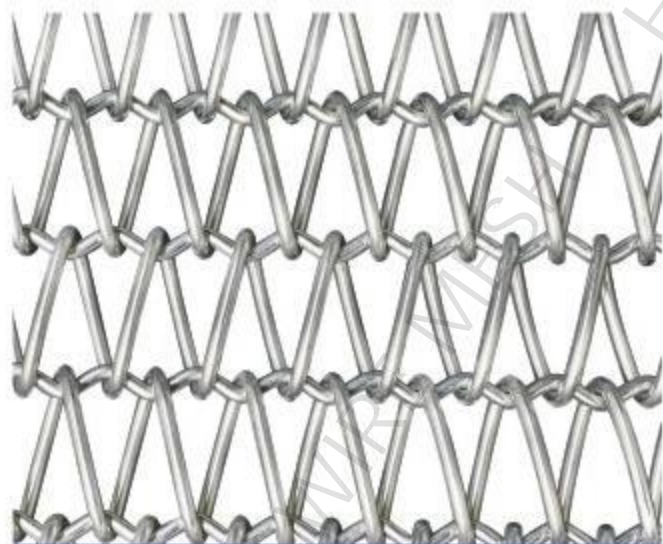

SXY-SS01

材质(Material):不锈钢SS304,316穿条直径(Cross diameter):1.5mm
螺条直径(Spiral diameter):1.5mm 穿条间距(Cross pitch):13mm
螺条间距(Spiral pitch):8mm 重量(Weight):6.1kg/m²

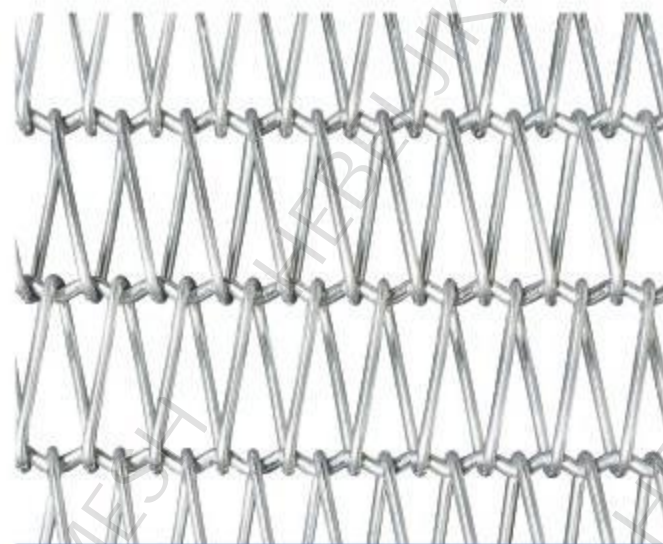

SXY-SS02

材质(Material):不锈钢SS304,316穿条直径(Cross diameter):1.5mm
螺条直径(Spiral diameter):1.2mm 穿条间距(Cross pitch):16mm
螺条间距(Spiral pitch):6mm 重量(Weight):5kg/m²

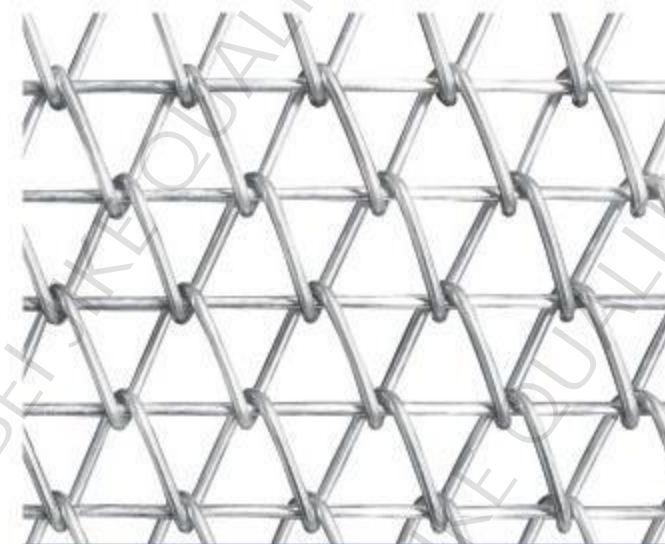

SXY-SS03

材质(Material):不锈钢SS304,316穿条直径(Cross diameter):1.5mm
螺条直径(Spiral diameter):1.5mm 穿条间距(Cross pitch):13mm
螺条间距(Spiral pitch):11mm 重量(Weight):7kg/m²



SXY-SS04

材质(Material):不锈钢SS304,316穿条直径(Cross diameter):1.5mm
螺条直径(Spiral diameter):1*1.7mm 穿条间距(Cross pitch):17mm
螺条间距(Spiral pitch):8mm 重量(Weight):5.4kg/m²

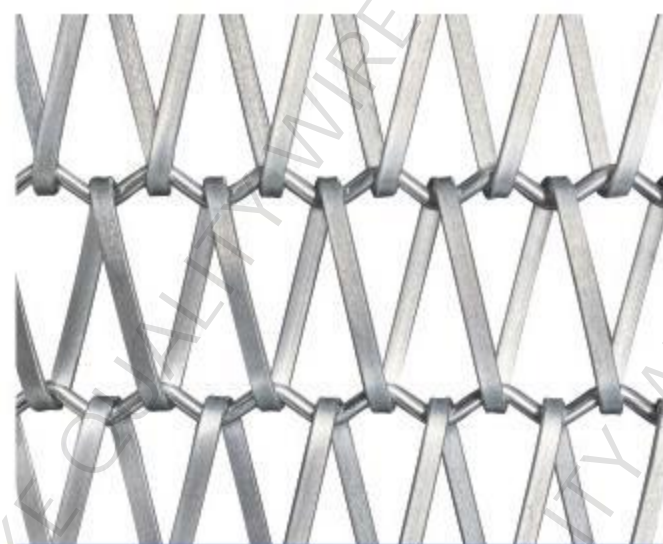

SXY-SS05

材质(Material):不锈钢SS304,316穿条直径(Cross diameter):2.0mm
螺条直径(Spiral diameter):1*2.5mm 穿条间距(Cross pitch):25mm
螺条间距(Spiral pitch):12mm 重量(Weight):5.1kg/m²

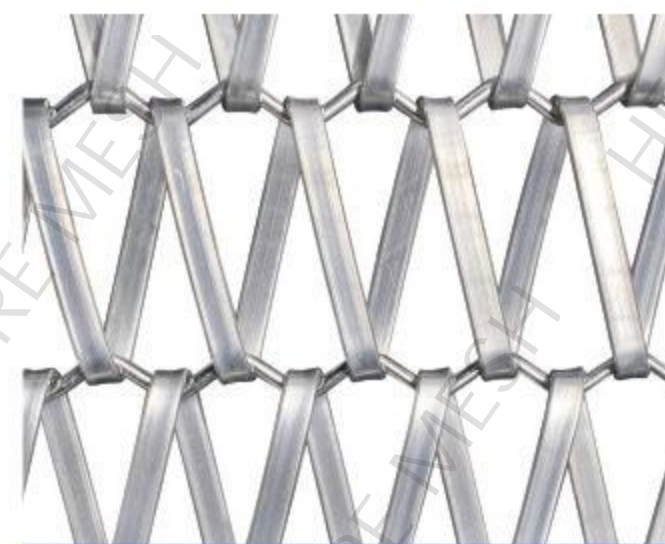

SXY-SS06

材质(Material):不锈钢SS304,316穿条直径(Cross diameter):2.0mm
螺条直径(Spiral diameter):1*4mm 穿条间距(Cross pitch):30mm
螺条间距(Spiral pitch):15mm 重量(Weight):6kg/m²

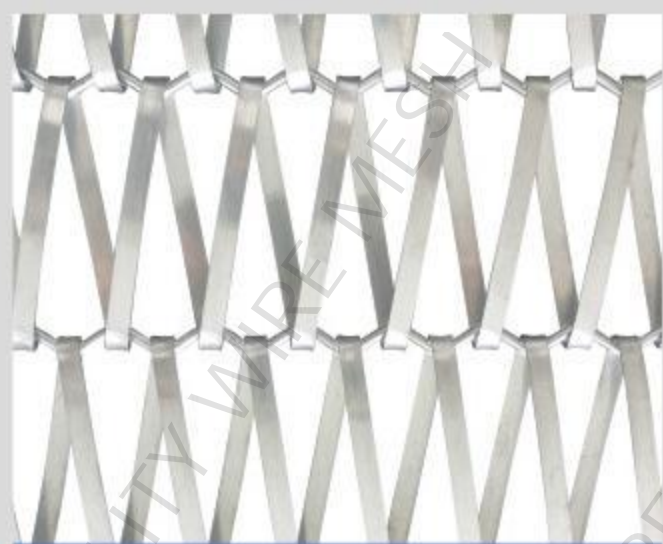

SXY-SS07

材质(Material):不锈钢SS304,316穿条直径(Cross diameter):3.0mm
螺条直径(Spiral diameter):1*6mm 穿条间距(Cross pitch):70mm
螺条间距(Spiral pitch):25mm 重量(Weight):5.2kg/m²

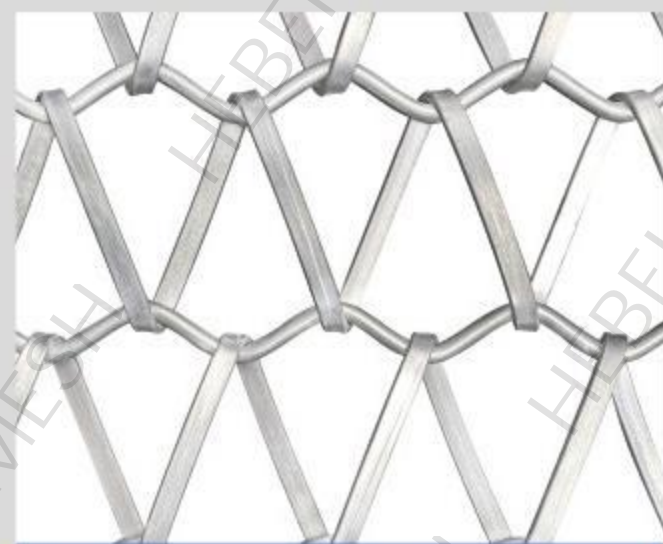

SXY-SS08

材质(Material):不锈钢SS304,316穿条直径(Cross diameter):3.0mm
螺条直径(Spiral diameter):1.5*4mm 穿条间距(Cross pitch):35mm
螺条间距(Spiral pitch):30mm 重量(Weight):5.6kg/m²

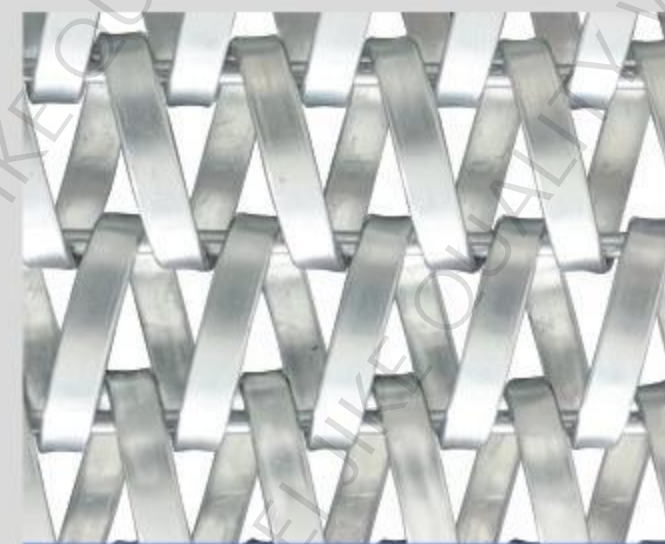

SXY-SS09

材质(Material):不锈钢SS304,316穿条直径(Cross diameter):2.0mm
螺条直径(Spiral diameter):1*4mm 穿条间距(Cross pitch):15mm
螺条间距(Spiral pitch):10mm 重量(Weight):12.3kg/m²

04 FOUR

金属环网

RING MESH

采用优质低碳钢、不锈钢、铜，手工连接而成。表面经过抛光或电镀着色处理，色彩鲜明，具有防火耐高温、耐腐蚀、随意造型等优点。

材质、圆环直径、颜色、尺寸均可按需定做。尺寸无限制。

金属环网广泛应用于隔断屏风、壁炉、窗帘、天花吊顶、内外幕墙等室内外装饰，部分用于防护用具。

Ring mesh is made of individually stainless steel rings that are intertwined with four adjacent rings, creating a very flexible, very stable, glossy mesh.

Since there are almost no limits to the possible application for our ring mesh thanks to its great flexibility and very special characteristics, we can manufacture all types and sizes for all sorts of different applications. Additional customized developments are available upon request.

Ring mesh is used widely for interior and exterior decoration as space dividers, partitions, fireplace mesh, mesh curtains, ceilings and so on.

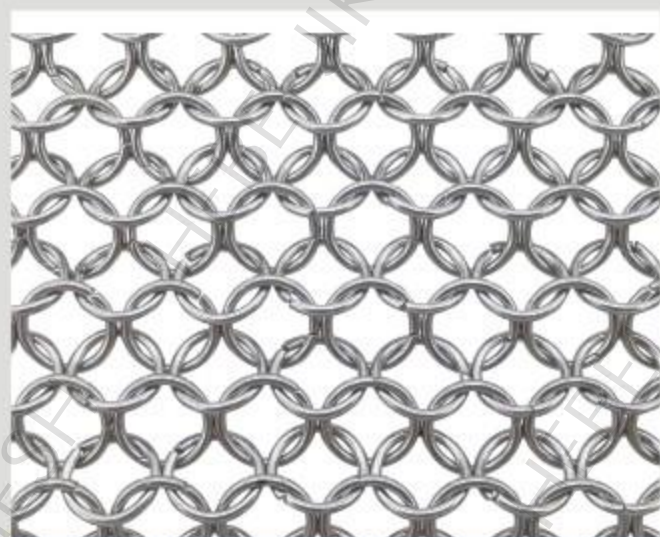

SXY-01

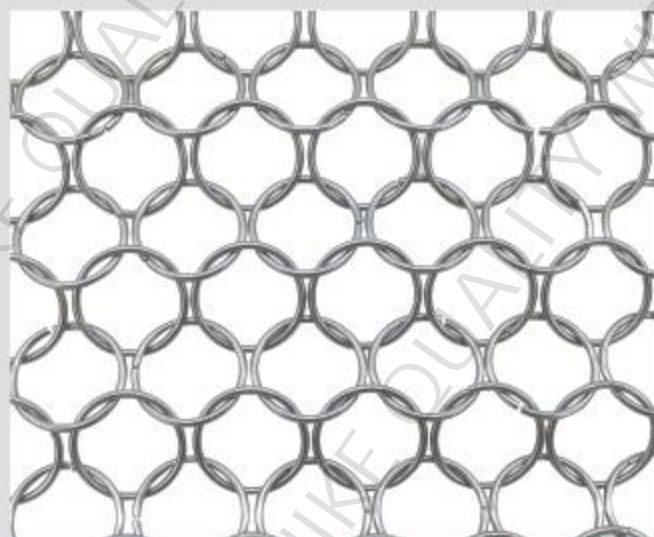

SXY-02

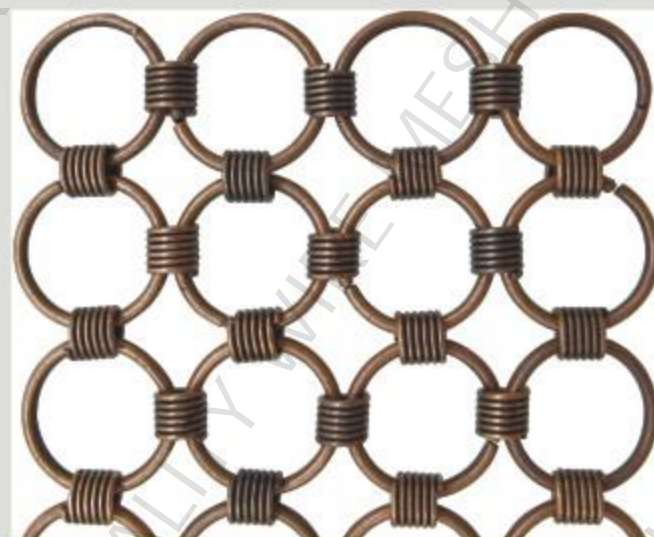

SXY-03

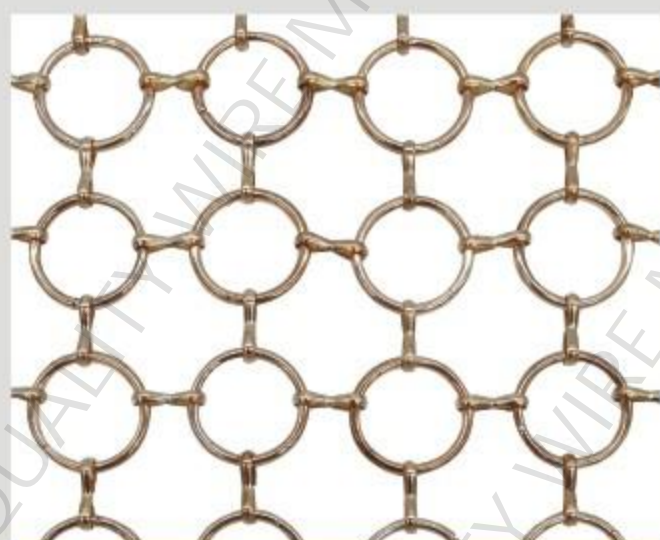

SXY-04



SXY-05

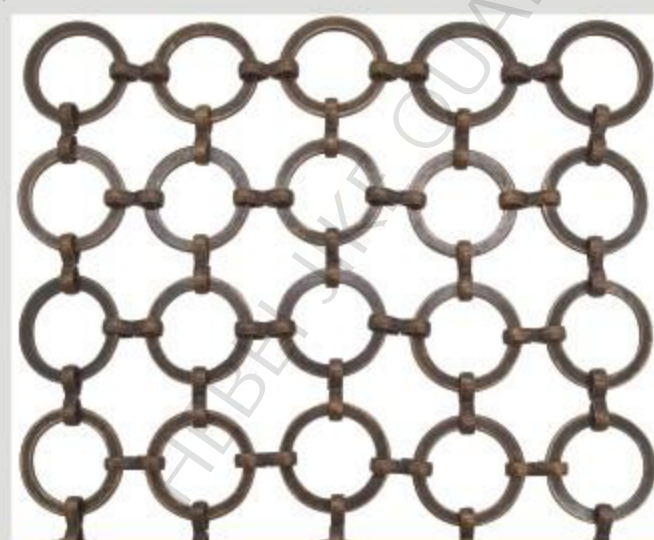

SXY-06

04 FOUR

效果展示

RESULTS SHOW

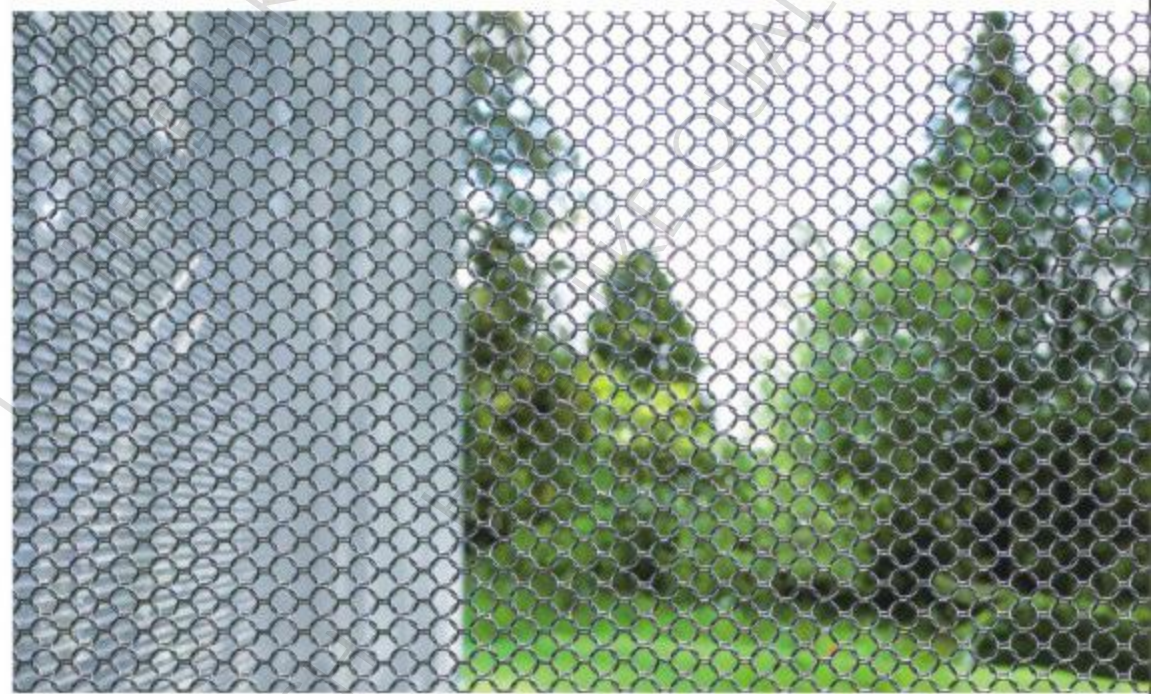
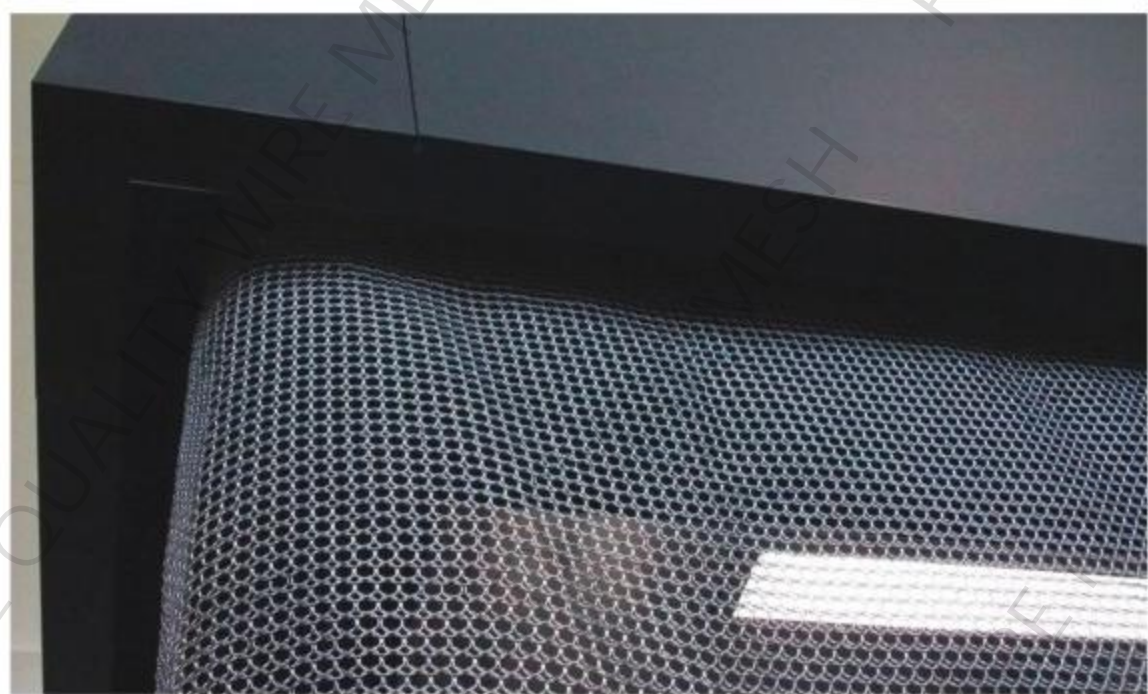

05 FIVE

艺术网

ART MESH

采用优质不锈钢丝、铜丝等材料编织而成。表面经过特殊着色处理，具有光泽度好、色彩丰富、重量轻、款式新等优点。

材质、颜色、尺寸均可按需定做，最宽4米，长度不限。

金属艺术网广泛应用于隔断屏风、吊顶、背景墙等室内装饰，也可做夹层玻璃。

Art mesh is produced in high grade stainless steel wire and copper wire by weave.

We can manufacture by your requirement. The width is max 4 meters, the length is no limited.

Art mesh is used widely for interior decoration as dividers, partition, ceilings, wall cladding, also laminated glass.



SXY-3025



SXY-3316T



SXY-SS12

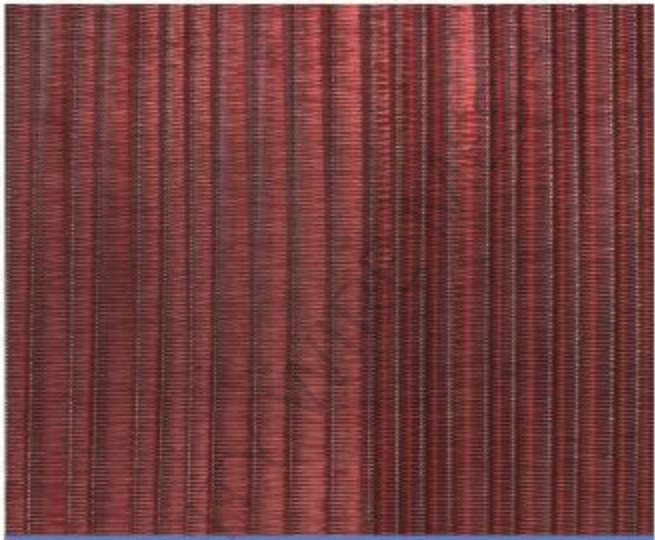

SXY-DB-32



SXY-DB-313

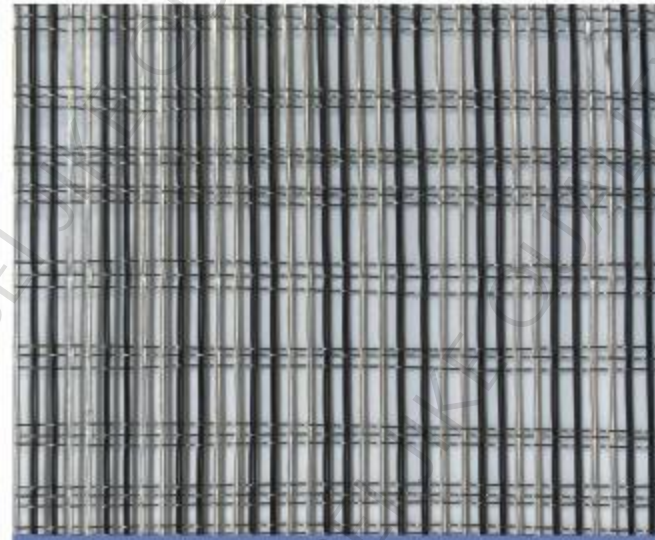

SXY-DBX-08

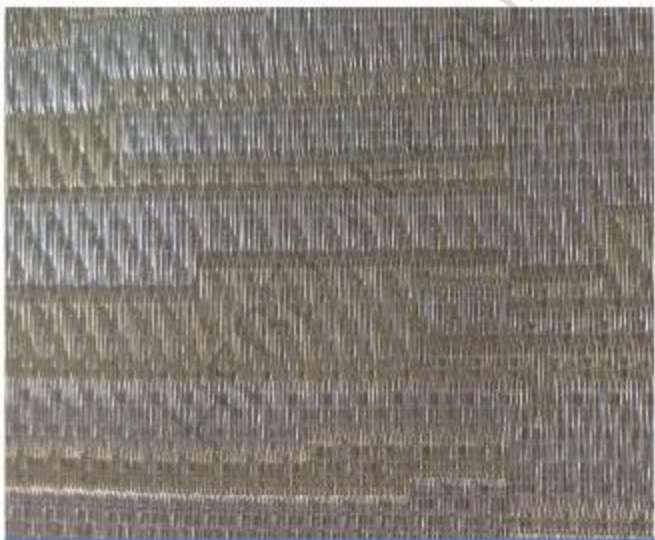

SXY-TH

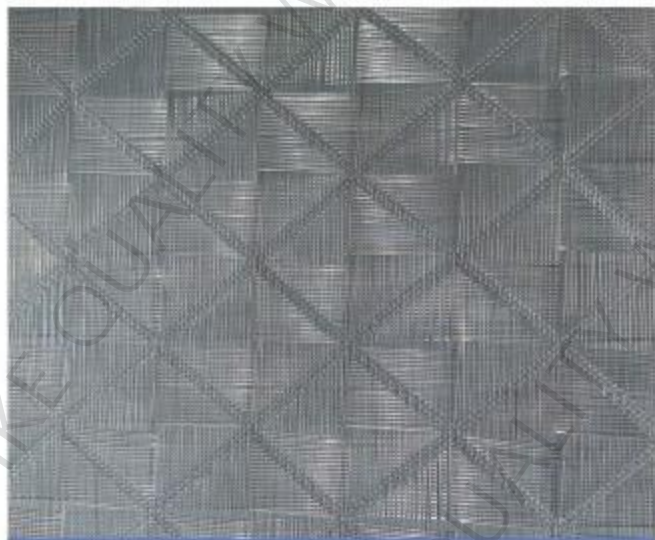

SXY-TH2



SXY-TH2-05



SXY-TH2-17A



SXY-TH-118



SXY-TH-38

06 SIX

铝勾帘

ALUMINUM CHAIN CURTAINS

采用优质铝合金材料制成，经过着色处理，具有耐腐蚀、耐高温、耐磨损、重量轻易安装等优点。尺寸、颜色均可按需定做，宽长无限制。铝勾帘广泛应用在隔断、屏风、窗帘、吊顶等室内外装饰。

The aluminium in the chain links goes through our special anodising treatment, specially designed for our chains, which gives them improved robustness and offers high colour resistance against climatic factors, wear and rusting. Also this electrochemical process fixes the colour to the aluminium chain, one of our outstanding characteristics is the wide range of colours we offer to our customers. The length and width is no limited. Aluminum chain curtains is used widely for interior and exterior decoration as space dividers, partitions, ceilings, wall covering, cladding, structures and so on.



07 SEVEN

不锈钢绳网

STAINLESS STEEL ROPE MESH

采用优质不锈钢丝绳，由不锈钢扣连接或手工交错编织而成，具有柔韧性好、线条独特、不生锈防腐蚀、通透性强、易安装等优点。常用不锈钢绳网的绳径：1.2、1.5、2.0、3.0、4.0等，常用不锈钢绳结构：7*7、7*19。常用网孔：20*20、25.4*25.4、30*30、40*40、60*60、100*100等。尺寸规格参数均可按需定做，宽度长度不限。不锈钢绳网广泛应用于吊顶、隔断、楼梯、桥梁围栏、建筑外墙、园林景观、动物围网等，既简洁美观又兼顾防护作用。

Stainless steel rope mesh can be divided into two kinds according to the combination method: knotted and ferrule. The former is combined by alternately crossed above and below. And the latter is combined by the ferrules which are made up from the same grade stainless steel. We can manufacture by your requirement. The standard mesh angle is 60°. The length and width is no limited.

Stainless steel rope mesh is used widely for ceilings, railings, bridge fence, wall facade, landscape, zoo enclosures and so on, that provide a safety barrier while maintaining its aesthetic appearance.



SXY-01



SXY-02



SXY-03

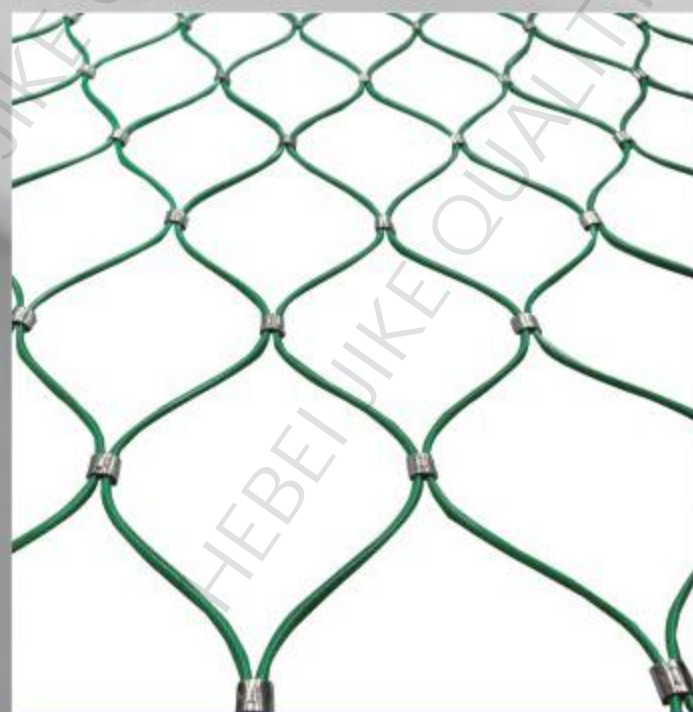

SXY-04

08 EIGHT

铝板网

ALUMINUM EXPANDED MESH



采用优质铝板经过冲压拉伸而成，表面经过着色或氧化，可呈现不同颜色。具有不生锈、重量轻、环保可回收等优点。

材质、板厚、梗宽、网孔均可按需定做，最宽2.5米，长度不限。
钢板网广泛应用于隔断、屏风、吊顶、内外幕墙等室内外装饰。

Aluminum expanded mesh is produced in aluminum sheet by punched and stretched.

We can manufacture by your requirement. The width is max 2.5 meters, the length is no limited.

Aluminum expanded mesh is used widely for interior and exterior decorations as dividers, partitions, ceilings, wall facades, coverings and so on.



SXY-01

材质(Material) : 铝Aluminium
板厚(Thickness) : 2.5mm 孔径(Aperture) : 40*100mm
梗宽(Strand) : 15mm 重量(Weight) : 5kg/m²



SXY-02

材质(Material) : 铝Aluminium
板厚(Thickness) : 3.0mm 孔径(Aperture) : 60*150mm
梗宽(Strand) : 17mm 重量(Weight) : 4.6kg/m²



SXY-03

材质(Material) : 铝Aluminium
板厚(Thickness) : 2.0mm 孔径(Aperture) : 70*230mm
梗宽(Strand) : 24mm 重量(Weight) : 3.7kg/m²



SXY-04

材质(Material) : 铝Aluminium
板厚(Thickness) : 1.5mm 孔径(Aperture) : 10*20mm
梗宽(Strand) : 3mm 重量(Weight) : 2.4kg/m²

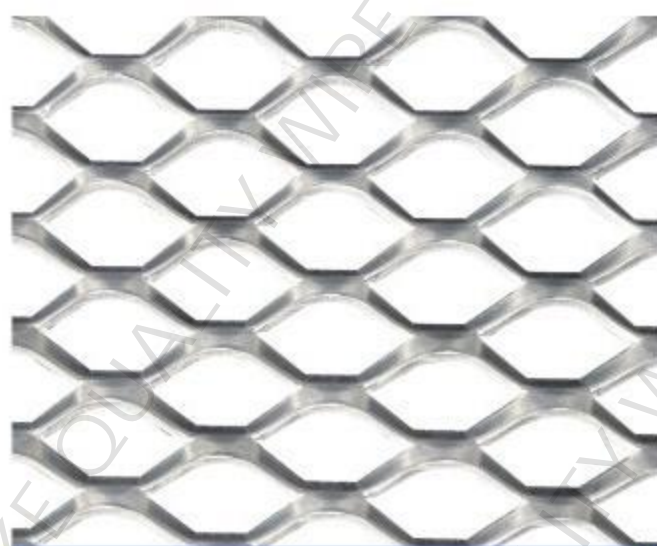

SXY-05

材质(Material) : 铝Aluminium
板厚(Thickness) : 1.5mm 孔径(Aperture) : 12*25mm
梗宽(Strand) : 3mm 重量(Weight) : 2.7kg/m²



SXY-06

材质(Material) : 铝Aluminium
板厚(Thickness) : 2.0mm 孔径(Aperture) : 10*50mm
梗宽(Strand) : 2.5mm 重量(Weight) : 2.7kg/m²



SXY-07

材质(Material) : 铝Aluminium
板厚(Thickness) : 2.0mm 孔径(Aperture) : 20*60mm
梗宽(Strand) : 3mm 重量(Weight) : 1.6kg/m²



SXY-08

材质(Material) : 铝Aluminium
板厚(Thickness) : 2.0mm 孔径(Aperture) : 12*120mm
梗宽(Strand) : 3.5mm 重量(Weight) : 3.1kg/m²



SXY-09

材质(Material) : 铝Aluminium
板厚(Thickness) : 1.0mm 孔径(Aperture) : 9*190mm
梗宽(Strand) : 2.5mm 重量(Weight) : 1.5kg/m²

09 NINE

冲孔网

PERFORATED MESH

采用优质低碳钢板、镀锌板、铝板、不锈钢板冲压而成，孔型有圆孔、方孔、三角孔、六边孔、异形孔等。表面经过抛光或着色，可与不同场景搭配，具有良好的通透性和吸音效果。

板厚、孔型、孔距均可按需定做，尺寸最宽1.5米，最长5米。

冲孔网广泛应用于隔断屏风、吊顶、内外幕墙等室内外装饰，在道路围栏（声屏障）、园林景观（花草爬架）、工业过滤等也应用广泛。

Perforated mesh is produced in mild steel plate,galvanized plate,aluminium plate and stainless steel plate by punched.

Perforation types are round holes,square holes,triangle holes,hexagon holes and special patterns.

We can manufacture by your requirement.The width is max 1.5meters,the length is max 5meters.

Perforated mesh is used widly for interior and exterior decorations as dividers,ceilings,wall covering,facades,and also road fencing(noise barrier),industrial filter etc.



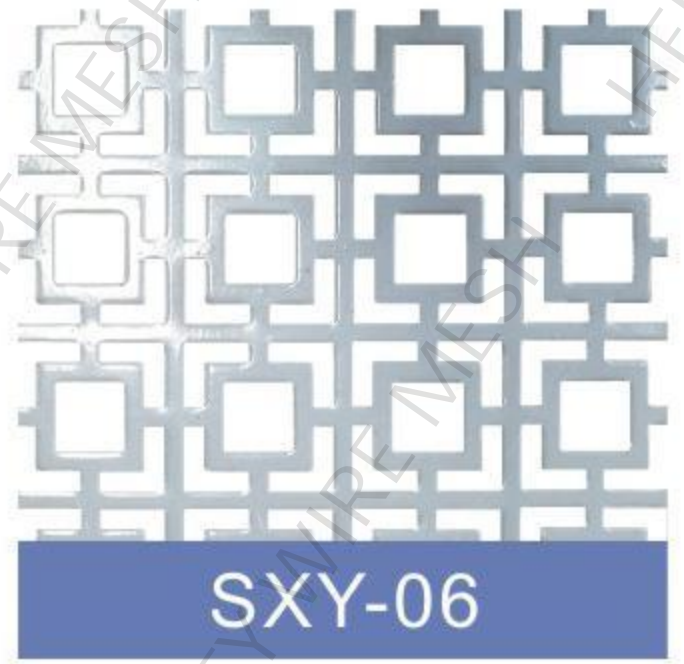
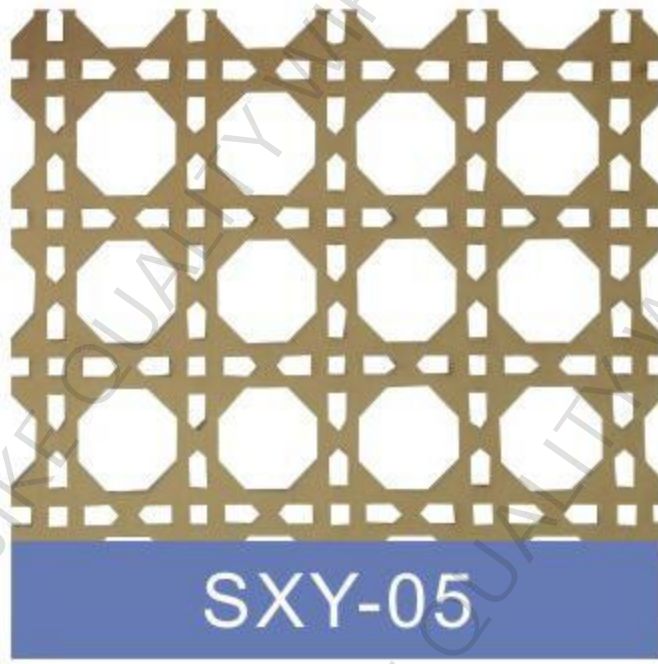
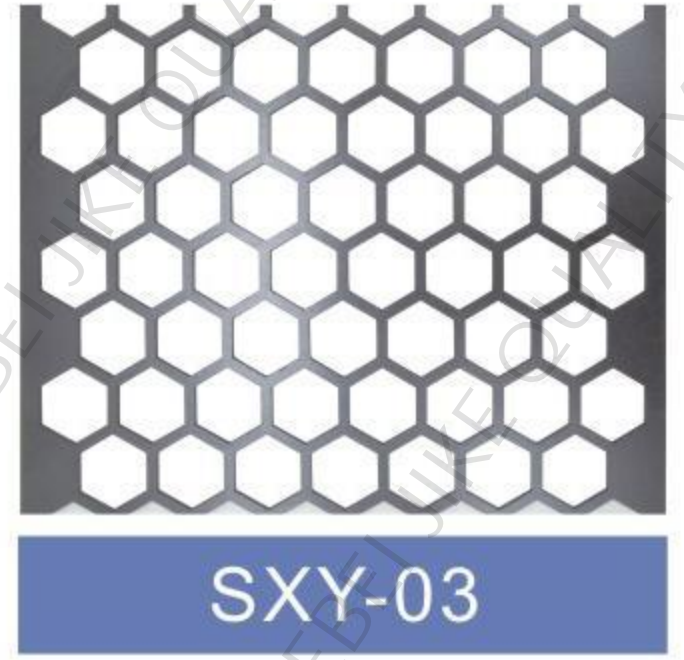
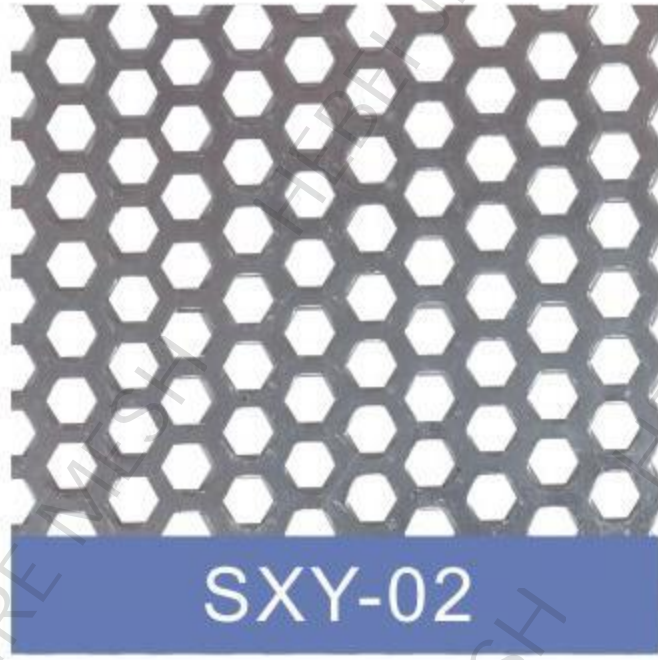
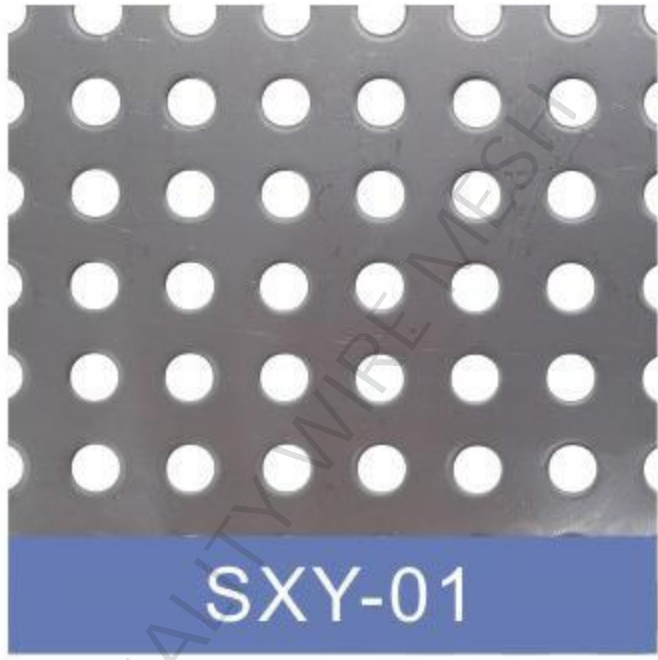

幕墙室内外装饰网安装图

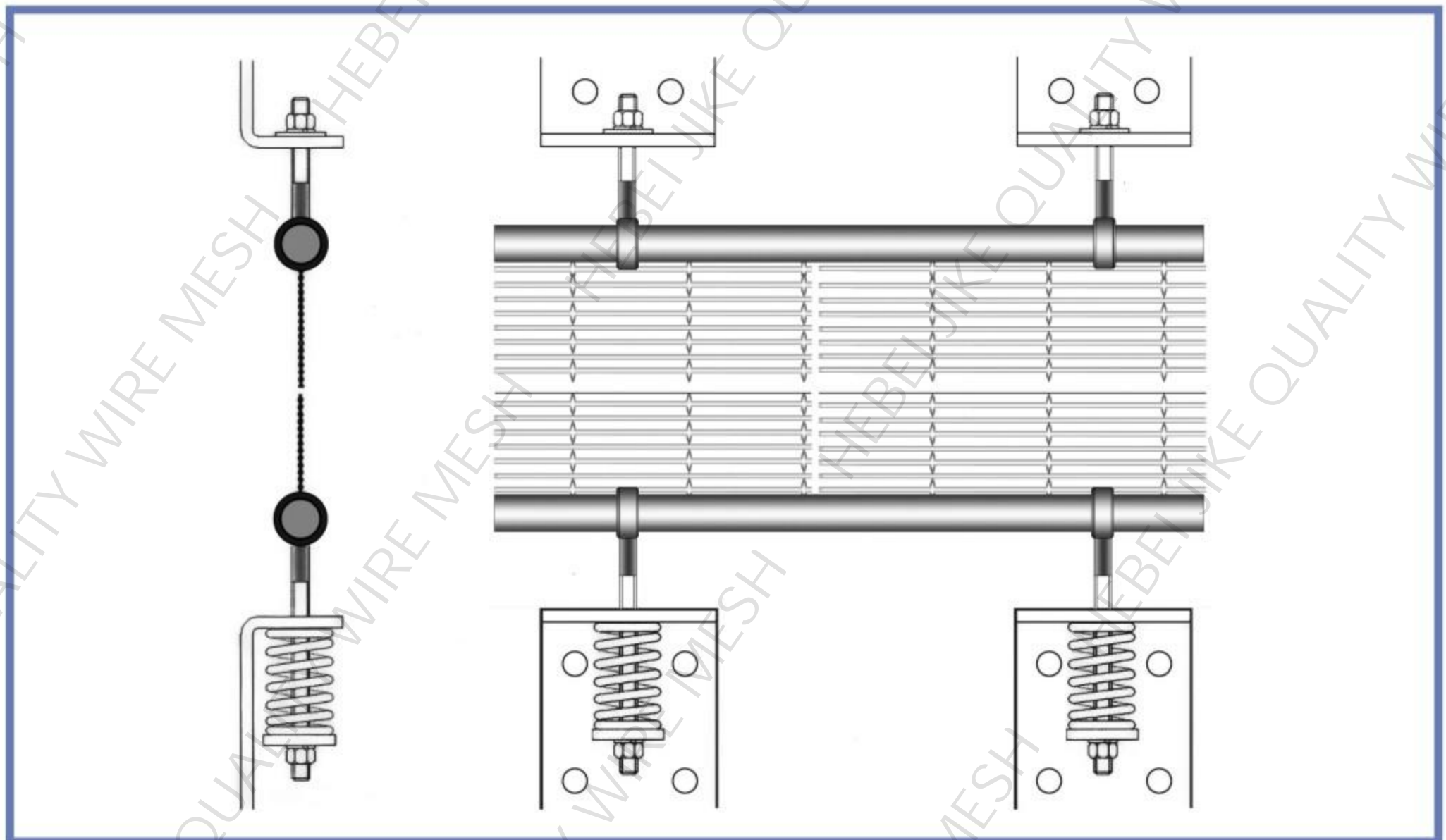
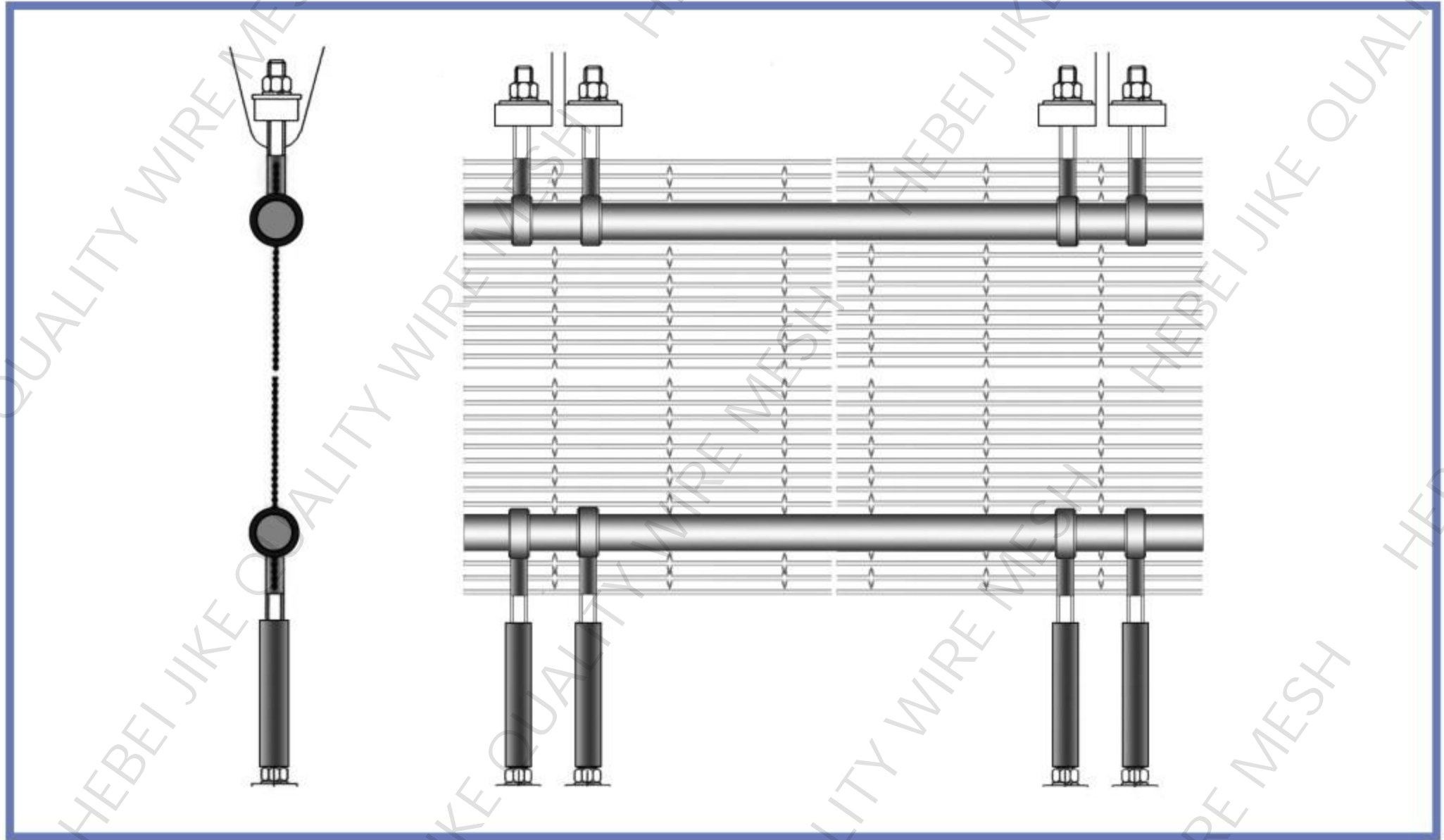

金属网帘安装示意图

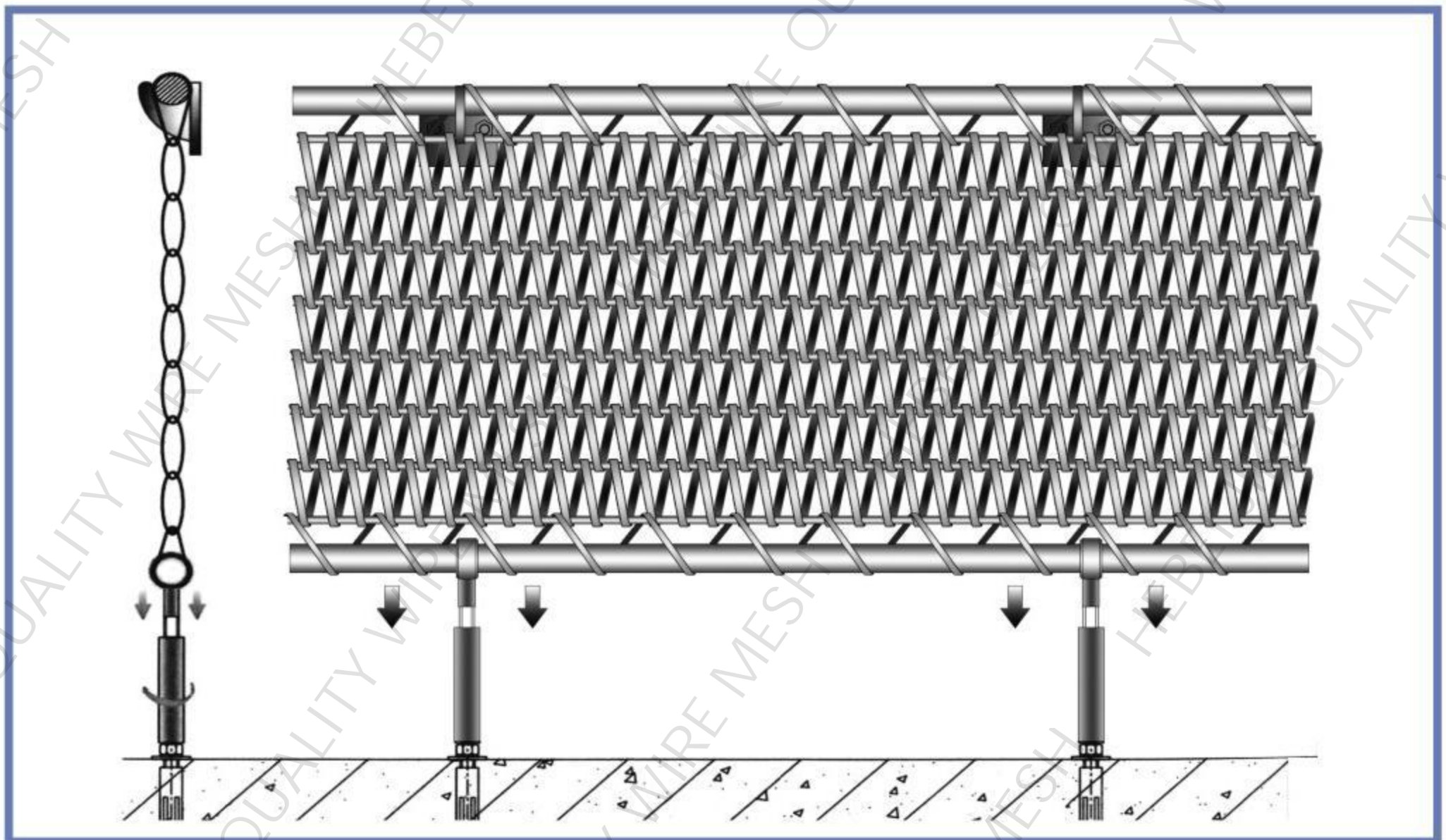
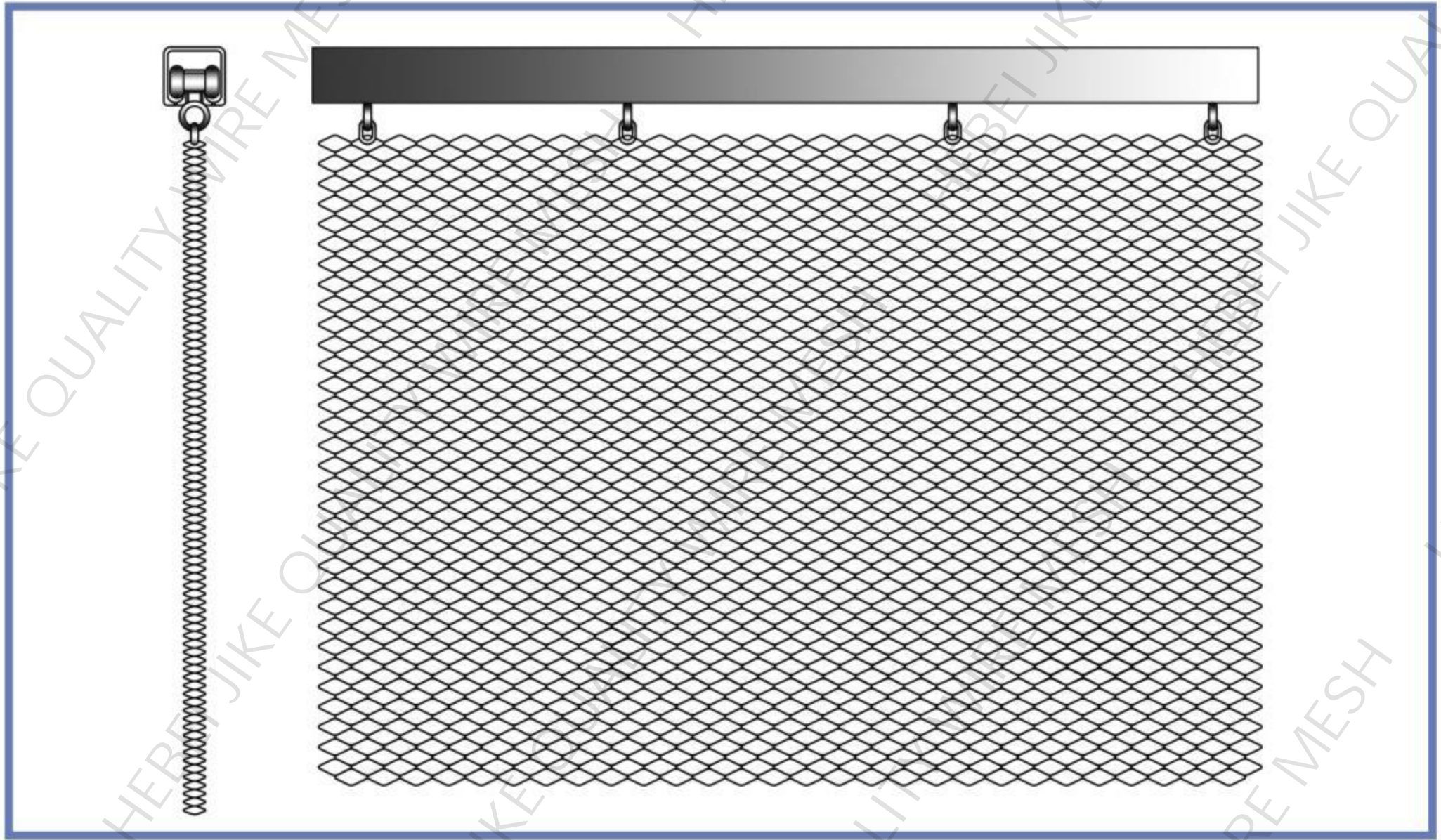



**WIRE MESH
QUALITY
JIKE**

HEBEI JIKE TRADE CO.,LTD

ZHONGKE INDUSTRIAL PRODUCTS CO.,LTD

ADD:BAONENG CENTER,SHIJIAZHUANG,HEBEI,CHINA 050899

TEL/WECHAT/WHATSAPP:+86-15831931141 +86-19930751141

Email: janeliu@qualitywiremesh.com jike01@qualitywiremesh.com

Web: www.qualitywiremesh.com