



HEBEI JIKE TRADE CO.,LTD
ZHONGKE INDUSTRIAL PRODUCTS CO.,LTD
ADD:BAONENG CENTER,SHIJIAZHUANG,HEBEI,CHINA 050800
TEL/WECHAT/WHATSAPP:+86-15831931141 +86-19930751141
Email: janeliu@qualitywiremesh.com Web: www.qualitywiremesh.com

Demister pad also called **mist pad**, **wire mesh demister**, **mesh mist eliminator**, **catching mist**, **mist eliminator**, is used in gas entrained mist separation column to guarantee the filtering efficiency.

Working principle of demister pad

When the gas with mist rises at a constant speed and passes through the wire mesh, the rising mist will collide with the mesh filament and attached to the surface filament due to the inertia effect. The mist will be diffuse on the filament surface and the droplet will follow along the filaments of the two wire intersection. The droplet will grow bigger and isolate from the filament until the droplets gravity exceeding gas rising force and liquid surface tension force while there is little gas passing through the demister pad.

Separate the gas in the droplets can improve the operating condition, optimize process indicators, reduce corrosion of the equipment, extend equipment life, increase the amount of processing and recovery of valuable materials, protect the environment, and decrease air pollution.

Mesh pad installation

There are two kinds of wire mesh demister pad, which are disk shaped demister pad and bar type demister pad.

According to different using condition, it can be divided into upload type and download type. When the opening is located in the above of the demister pad or when there is no opening but has flange, you should choose the upload demister pad.

When the opening is in the below of the demister pad, you should choose the download type demister pad.



HEBEI JIKE TRADE CO.,LTD
ZHONGKE INDUSTRIAL PRODUCTS CO.,LTD
ADD:BAONENG CENTER,SHIJIAZHUANG,HEBEI,CHINA 050800
TEL:WECHAT/WHATSAPP:+86-15831931141 +86-19930751141
Email: janeliu@qualitywiremesh.com Web: www.qualitywiremesh.com

Upload type demister pad

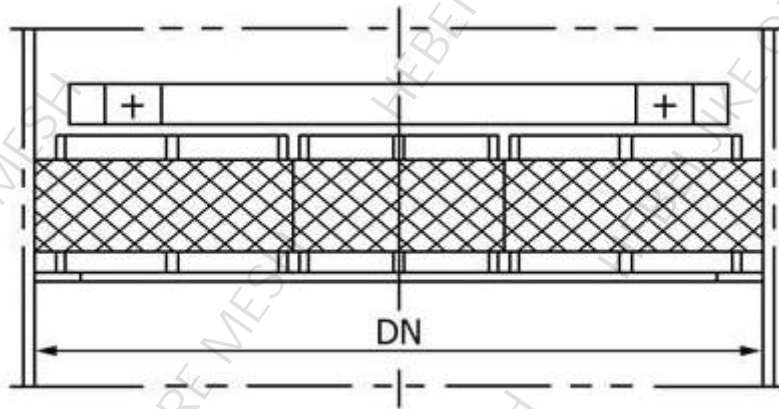

Download type demister pad

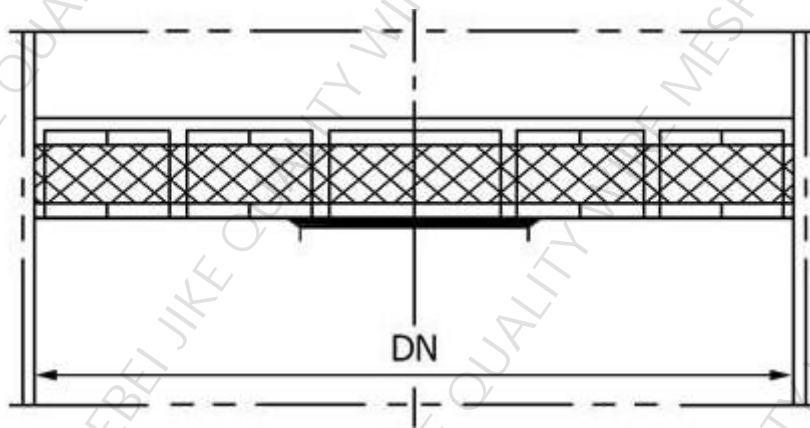

Horizontal separation tower

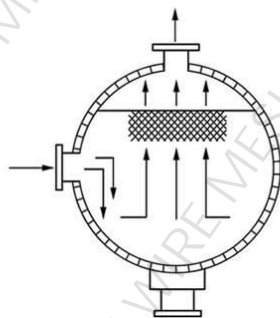

Spherical separation tower

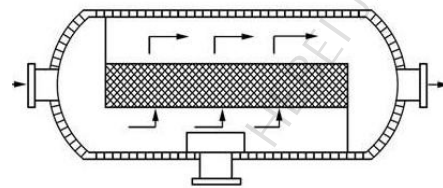



HEBEI JIKE TRADE CO.,LTD
ZHONGKE INDUSTRIAL PRODUCTS CO.,LTD
ADD:BAONENG CENTER,SHIJIAZHUANG,HEBEI,CHINA 050800
TEL/WECHAT/WHATSAPP:+86-15831931141 +86-19930751141
Email: janeliu@qualitywiremesh.com Web: www.qualitywiremesh.com

Scrubber

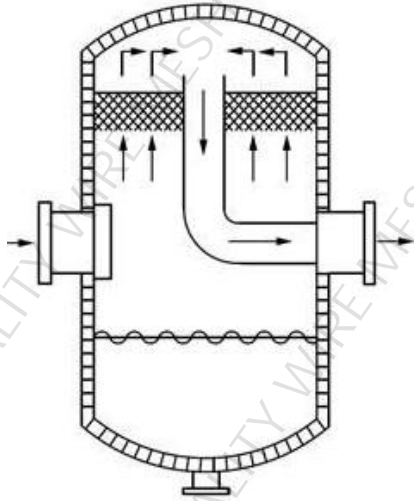

Distillation column.

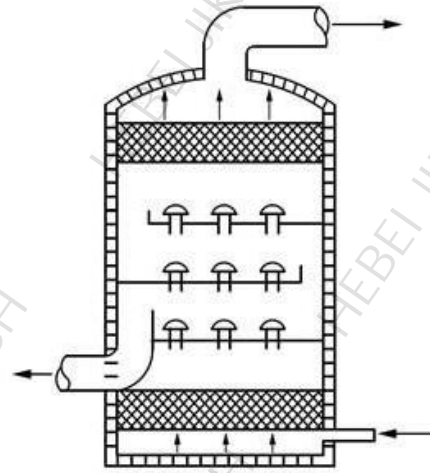

Vertical separation column

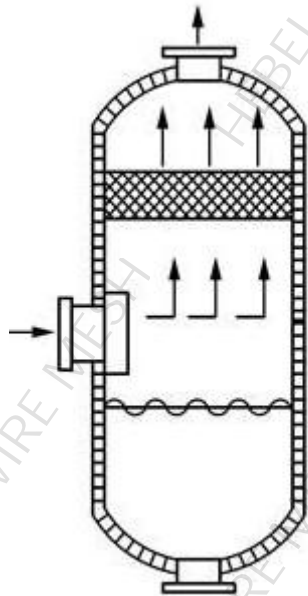

packed tower

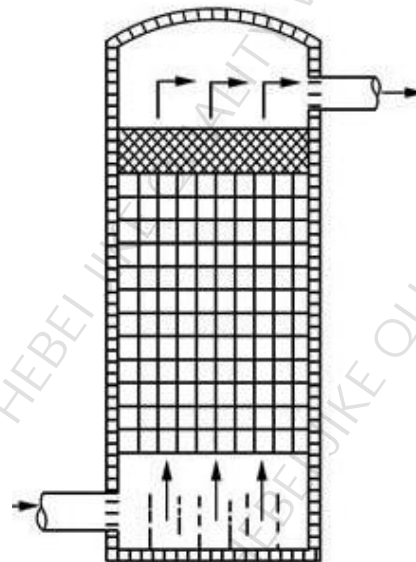



HEBEI JIKE TRADE CO.,LTD

ZHONGKE INDUSTRIAL PRODUCTS CO.,LTD

ADD:BAONENG CENTER,SHIJIAZHUANG,HEBEI,CHINA 050800

TEL/WECHAT/WHATSAPP:+86-15831931141 +86-19930751141

Email: janeliu@qualitywiremesh.com Web: www.qualitywiremesh.com

Style	Density kg/m3	Free Volume %	Surface Area m2/m3	Metex	York	Becoil	Knitmesh	Vico-Tex	Uop	Koch	Acs	GOTO SHOJI
H	80	99	158	Hi-Thruput	931	954	4536	160	B	511	7CA	H155
L	120	98.5	210		422							
N	144	98.2	280	Nu-Standard	431		9030	280	A	911	4CA	S275
SN	128	98.4	460		326			415		706		
SL	193	97.5	375	Xtra-Dense	421	890	9033	380	C	1211	4BA	S370
SM	300	96.2	575									
SH	390	95	750									S740
T	220	97.2	905									
R	432	94.5	1780	Multi-Strand	333			800				M1740
W	220	97.2	428	Wound								M905
GS	160	96.7	5000		371							



HEBEI JIKE TRADE CO.,LTD

ZHONGKE INDUSTRIAL PRODUCTS CO.,LTD

ADD:BAONENG CENTER,SHIJIAZHUANG,HEBEI,CHINA 050800

TEL/WECHAT/WHATSAPP:+86-15831931141 +86-19930751141

Email: janeliu@qualitywiremesh.com Web: www.qualitywiremesh.com

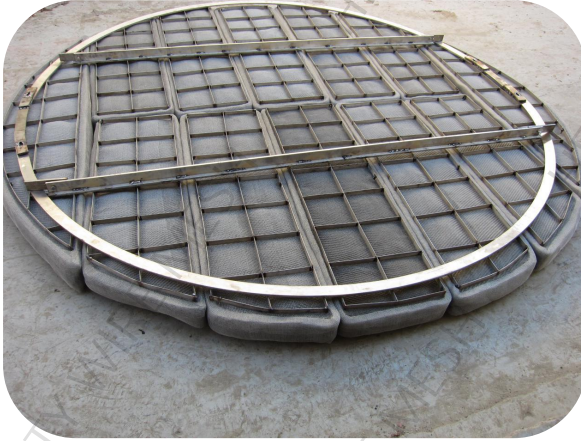



HEBEI JIKE TRADE CO.,LTD
ZHONGKE INDUSTRIAL PRODUCTS CO.,LTD
ADD:BAONENG CENTER,SHIJIAZHUANG,HEBEI,CHINA 050800
TEL/WECHAT/WHATSAPP:+86-15831931141 +86-19930751141
Email: janeliu@qualitywiremesh.com Web: www.qualitywiremesh.com





HEBEI JIKE TRADE CO.,LTD

ZHONGKE INDUSTRIAL PRODUCTS CO.,LTD

ADD:BAONENG CENTER,SHIJIAZHUANG,HEBEI,CHINA 050800

TEL/WECHAT/WHATSAPP:+86-15831931141 +86-19930751141

Email: janeliu@qualitywiremesh.com Web: www.qualitywiremesh.com





HEBEI JIKE TRADE CO.,LTD
ZHONGKE INDUSTRIAL PRODUCTS CO.,LTD
ADD:BAONENG CENTER,SHIJIAZHUANG,HEBEI,CHINA 050800
TEL/WECHAT/WHATSAPP:+86-15831931141 +86-19930751141
Email: janelu@qualitywiremesh.com Web: www.qualitywiremesh.com

